

Gas-Fired Condensing Hot Water Boiler

De Dietrich Gas 310/610 ECO Series



Gas 310 ECO

Boiler may not be exactly as illustrated.

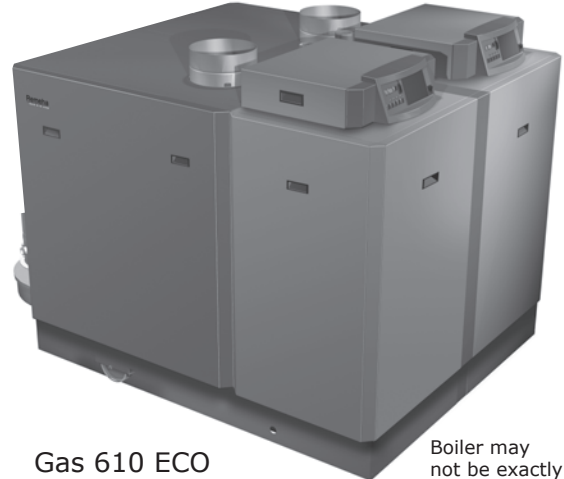

Gas 610 ECO

Boiler may not be exactly as illustrated.

- Fully modulating (5:1) 20-100%
- Cast Aluminum sectional boiler
- Reduced emissions
- Compact and light weight design
- Broad output range from 63 to 3,911 MBH/18 to 1,146 kW or more in cascade installations
- Gas 310 ECO - 5 models
- Gas 610 ECO - 4 models

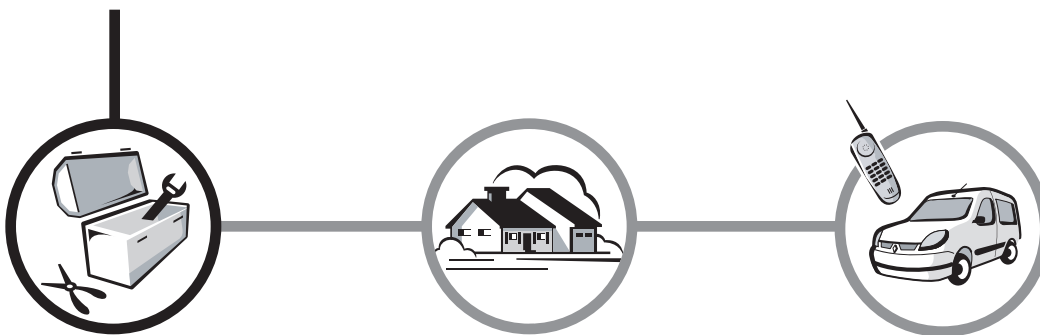

Installation and Operating Manual



De Dietrich
B O I L E R S

 **Warning:**

Before you operate this boiler, read this manual carefully and take extra precautions to all safety and warning symbols or important items. The operating manual is part of the documentation along with the boiler. The installer is required to explain your heating system and boiler operating instructions.

 **Notice:**

Please read this manual and retain for future reference. Improper installation, adjustment, alteration, service or maintenance can cause injury, loss of life or property damage. Refer to this manual for assistance or additional information or consult a qualified installer, service agency or the gas supplier.

 **important:**

This is a category II or IV boiler, only use an approved type 'BH' vent material or equivalent, consult the venting section in this manual

In the interest of customers, DE DIETRICH & DDR Americas are continuously endeavoring to make improvements in product quality.

All the specifications stated in this document are therefore subject to change without notice

TABLE OF CONTENTS

PREFACE		5
1. SAFETY INSTRUCTIONS		6
1.1	Symbols	6
	General Instructions	6
	Modifications – Spare parts	6
2. DESCRIPTION OF BOILER		7
3. DESIGN		8
3.1	Boiler version	8
3.2	Operating principle	9
4. TECHNICAL DATA		10
4.1	Dimensions	10
4.2	Technical data	11
4.3	Quotation specifications	16
4.4	Delivery options	16
4.5	Gas 610 Quotation Specification	17
4.6	Delivery and ordering options	17
5. EFFICIENCY INFORMATION		18
5.1	Combustion efficiency	18
5.2	Thermal efficiency	18
5.3	Standby losses	18
6. APPLICATION DATA		18
7. INSTALLATION INSTRUCTIONS		18
7.1	General	18
7.2	Delivery and installation	18
7.3	Flue gas discharge and air supply	21
7.3.1	General	21
7.3.2	Boiler venting types	21
7.3.3	Venting options	21
7.3.4	Vent terminations	21
7.3.5	Combustion air supply requirements	21
7.3.6	Chimney & CLV systems	22
7.3.7	Direct vent or DVS systems	23
7.3.8	Co-venting precautions	24
7.3.9	Vent terminations precautions	25
7.4 INSTALLATION DETAILS		26
7.4.1	Water pressure	26
7.4.2	Condensate discharge	26
7.4.3	Water treatment	26
7.4.4	Safety relief valve	26
7.4.5	Water flow & content	26
7.4.6	Noise pollution	26
7.5	Multiple boiler installation	26
7.6	Typical water system layout	27
8. INSTALLATION INSTRUCTIONS FOR ELECTRICAL INSTALLER		28
8.1	General	28
8.2	Electrical specifications	28
8.2.1	Main power voltage	28
8.2.2	Control unit	28
8.2.3	Power consumption	28
8.2.4	Fuse ratings	29
8.2.5	Temperature control	29
8.2.6	Low water level protection	29
8.2.7	Hi-Limit protection	29
8.2.8	Air pressure differential sensor	29

8.3	Connections	30
8.4	Wiring diagram	31
8.5	Sequence of operation	34
8.6	Boiler control	34
8.6.1	Gas 310 Introduction	34
8.6.2	Gas 310 Modulating controls general	35
	A. Single boiler	35
	B. Multiple boiler	35
8.6.3	BMS Analog control	35
8.6.4	On/Off control	36
8.6.5	High/Low control	36
8.6.6	2-Stage control	37
8.6.7	4-Stage High/low control	37
8.7	Other inputs	37
8.7.1	Shutdown input	37
8.7.2	Lockout input	37
8.7.3	External interlock	37
8.7.4	Other Outputs	38
8.7.5	Analog output	38
8.7.6	Operational signal	38
8.7.7	Common alarm	39
8.7.8	External gas valve	39
8.8	Optional inputs	39
8.8.1	System pressure sensor	39
8.8.2	Gas valve leak proving system	39
8.8.3	Low gas pressure switch	39
8.8.4	Flue gas damper	40
8.8.5	Return butterfly valve	40
8.9	Other connections	40
8.9.1	Boiler or system pump control	40
8.9.2	Frost protection	40
9. GAS INSTALLATION INSTRUCTIONS		41
9.1	Gas connection	41
9.2	Gas pressure	41
9.3	Gas/air ratio control	41
10. COMMISSIONING		42
10.1	Initial lighting	42
10.2	Shutdown	45
11. CONTROL AND SAFETY EQUIPMENT		46
11.1	General	46
11.1.1	Instrument panel layout	46
11.1.2	LED indicators	47
11.2	Switch function key	47
11.2.1	Manual/Automatic operation	47
11.2.2	Forced High mode	47
11.2.3	Forced Low mode	47
11.3	Display of values	48
12. OPEARATING MODE		48
12.1	Operating mode	48
12.2	Read out mode	49
12.3	Control strategy	50
12.4	Shut-off	50
12.4.1	Shut-off	50
12.4.2	Shut-off mode	50
12.5	Counter mode	51
12.5.1	General	51
12.5.2	Reading out counter mode	51
13. SETTING MODE		52
13.1	User level setting mode	52
13.1.1	Flow temperature	52
13.1.2	Pump run on time	53
13.1.3	Boiler control	53
13.2	Setting mode service level	53

	Table 16 – Service level setting mode	54
13.2.1	Minimum fan speed	55
13.2.2	Maximum fan speed	55
13.2.3	Forced part load time	55
13.2.4	Cycling prevention delay time	55
13.2.5	Required flow temperature	55
13.2.6	Switch point high/low operation	55
13.2.7	Shunt pump post-purge time	55
13.2.8	ΔT from control stops point to start point (E)	56
13.2.9	Maximum flue gas temperature	56
13.2.10	High limit temperature setting	56
13.2.11	Modulation start point at ΔT	56
13.2.12	Minimum water pressure	56
13.2.13	Adjustments option/accessory	56
13.2.14	Low speed with H/L control	57
13.2.15	Boiler type	57
14. FAULT-FINDING		58
14.1	General	58
14.2	Failure mode	58
14.3	Cooling mode	58
14.4	Summary of failure (lock-out)	59
	Table 23 Failure codes	60
15. INSPECTION AND MAINTENANCE		61
15.1	General	61
15.2	Cooling mode	61
15.3	Annual inspection	61
15.4	Maintenance	62
15.4.1	Inspection of air box and dirt trap	62
15.4.2	Non return valve cleaning	62
15.4.3	Venturi cleaning	62
15.4.4	Fan cleaning	63
15.4.5	Heat exchanger cleaning	63
15.4.6	Burner assembly cleaning	63
15.4.7	Condensate collector cleaning	64
15.4.8	Condensate siphon cleaning	64
15.4.9	Ignition/ionization electrode cleaning	64
15.4.10	Gas filter check	65
15.4.11	Inspection glass cleaning	65
15.5	Explode part view	66
15.5.1	Spare parts listing	67
16. APPENDICES		69
16.1	Control menu	70
16.2	shut-off codes	71
17. COMMISSIONING & MAINTANENCE		73
17.1	Boiler commissioning report	73
17.2	Boiler control settings	74
17.3	Routine maintenance checklist	74

PREFACE

Read these instructions carefully, before putting the boiler into operation, familiarize yourself with its control functions, operation and strictly observe the instructions given. Failure to do so may invalidate warranty or prevent the boiler from operating.

The Installation and commissioning of the boiler needs to be performed by a licensed and trained heating contractor. A complete commissioning report must be performed, recorded and sent to DDR Americas Inc. for successfully active the product warranty, the startup report and any service records will be requested when any warranty claims are made.

If you have any questions or require more information about specific subjects relating to this boiler or its installation please do not hesitate to contact us.

The data published in these technical instructions is based on the latest information (at date of publication) and may be subject to revisions.

We reserve all the right to continuous development in both design and manufacture, therefore any changes to the technology employed may not be retrospective nor may we be obliged to adjust earlier supplies accordingly.



Fig 01 – Gas 310 ECO 3D. Gas 610 ECO consists of one Gas 310-L (left hand) and one Gas 310-R (right hand).

1 SAFETY INSTRUCTIONS

1.1 Symbols

The following symbols are used in this document to emphasize certain instructions. This is in order to increase your personal safety and to safeguard the technical reliability of the boiler.

 Instructions must be followed closely to avoid personal injury or serious damage to the unit or the environment.

 **Important!!**

Instructions are of essential importance for the correct functioning of the unit.

 = Indicates danger of electrical shock. Serious personal injury may occur.

 **Read and familiarize yourself with these instructions:**

Instructions contain useful information

General Instructions

Keep unauthorized personnel away from the boiler. Do not place objects on or against the boiler. Do not touch hot water connections or the flue outlet when the boiler is operating – burn hazard.

 **Danger**

This boiler is connected to a 120v power supply. An improper installation or attempts to repair electrical components or controls may result in life threatening situations.

 **WHAT TO DO IF YOU SMELL GAS:**

- Do not smoke and make no fire or sparks;
- Do not operate electrical switches
- Do not use any phone in the building
- Immediately call your gas supplier from another building. If the gas supplier is not available, call 9-1-1

 **Warning!**

Follow the gas supplier's instructions.

 **Be aware of flue gas leaks**

If you smell flue gas fumes, turn the boiler off and contact your service company or installer.

 **Beware of water leaks**

If you see water leaking from the boiler, turn it off and contact your service company or installer.

 **Working on the boiler**

Installation, commissioning, maintenance and repair work must only be carried out by a licensed and qualified technician. Designed and engineered in accordance with all relevant national/local standards and certifications.

Always disconnect the main power supply and close the main gas cock before working on the boiler.

Casing panels should only be removed for maintenance and servicing purposes. Refit all panels on completion of maintenance or servicing before putting the boiler back into service.

Instructions and warning labels on the boiler must never be removed or covered and must be clearly legible throughout the entire service life of the boiler. Damaged or illegible instructions and warning labels must be replaced immediately.

Generally applicable safety instructions related to accident prevention must be consulted in addition to the information supplied in this technical documentation.

Boiler modification and spare parts

The boiler must not be modified or fitted with non OEM spare parts without the express written approval of DDR Americas Inc. [De Dietrich Boilers].

2 GENERAL DESCRIPTION OF BOILER

The Gas 310/610 ECO boiler is a fully assembled, free standing, gas fired (natural gas only), fully modulating, high efficiency condensing boiler and is supplied, plastic wrapped, crated on a pallet.

The sectional cast aluminum heat exchanger and other major components are contained within a rigid steel frame with removable casing parts for maintenance purposes. The Gas 310/610 ECO frame is fitted with a set of casters to enable the assembled unit to be easily maneuvered into position within the plant room on site with minimum effort. All major electrical and electronic controls are contained within the instrument panel mounted on top of the boiler at the opposite end to the connections facing to the front (long side).

The boiler is available with flow and return connections on the right hand end of the boiler, with the gas connection on the top of the boiler. The flue gas outlet c/w a condensate connection will be at low level on the same side as the connections. Combustion air inlet (from room sealed operation) is located at the top of the boiler. The front or “service side” of the boiler provides access to the heat exchanger inspection hatch and other service items, see fig. 02 and fig. 04.

The boiler is suitable for room-sealed or open flue applications and has been designed for central heating and indirect hot water production at working pressures not exceeding 100 psig [6.8 bar]. It must be installed on a fully pumped system and is designed for operating pressures between 11 – 100 psig [0.8 – 6.8 bar]. The boiler is to be used for indoor installations only.

The pre-mix gas burner (NG only) with its gas/air ratio control system ensures clean, trouble free operation with higher than average efficiencies of up to 99.9% in the condensing mode combined with ultra low NO_x and minimum CO emissions.

The standard control package allows for external On/Off, High Low (volt free switch/s) or modulating control (0-10V input). The built in digital display shows normal operating/fault code indication and allows actual and set values to be read and adjusted.

The intelligent, advanced boiler control (‘**abc**^(R)’) continuously monitors the boiler operating conditions, varying the heat output to suit the system load. The control is able to react to external “negative” influences in the rest of the system (flow rates, air/gas supply problems) maintaining boiler output for as long as possible without resorting to a lock out condition. At worst the boiler will reduce its output and/or shut down (shut off mode) awaiting the “negative” conditions to return to normal before re-starting.

The ‘**abc**®’ control cannot override the standard flame safety controls.

All Gas 310/610 boilers are fully test fired after assembly to ensure the boiler and controls comply with our strict quality policy.

The packaged boiler is constructed and approved according to the following standards:

- ANSI Z21.13 / CSA 4.9
- UL 795
- CGA CAN1-3.1
- ASME Section IV
- CRN for each Canadian Province
- Electrical according CSA 22.2 & NEC/NFPA 70
- Gas Vent Category II & IV – Use vent type BH
- Consult factory for other certifications or qualifications.

3 DESIGN

3.1 Boiler Version

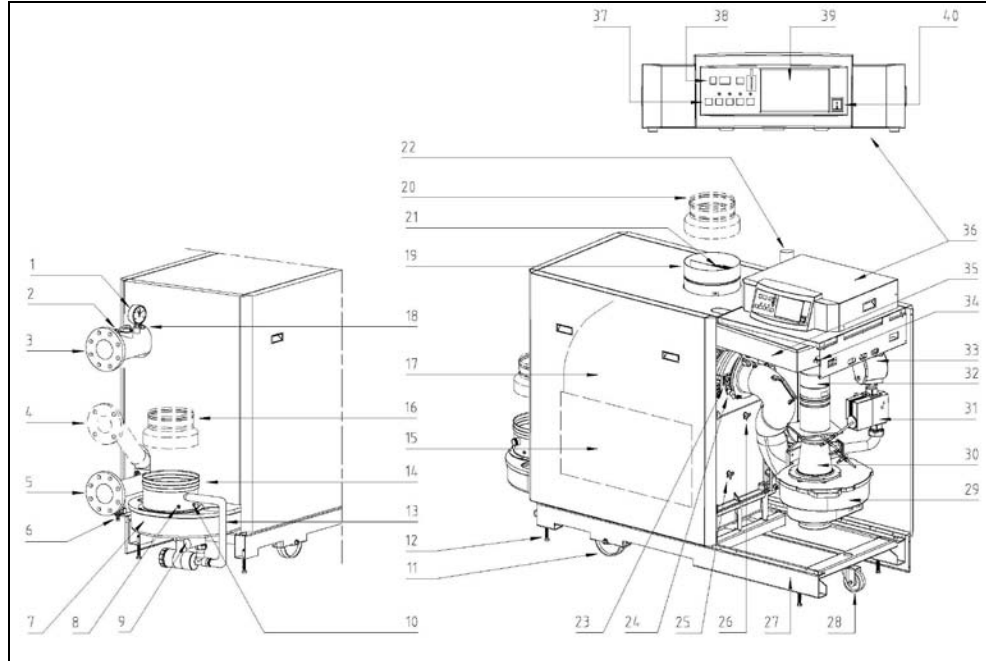

Fig. 02 Cross-section Gas 310 ECO (Left hand boiler illustrated). Gas 610 boiler consists of Gas 310-L and Gas 310-R.

The service side of the boiler (with the heat exchanger inspection cover) is the front.

- | | |
|---|--|
| 1. T/P gauge (supply manifold) | 24. Ignition/Ionization electrode |
| 2. Relief valve 1 ½ In. & additional ½ In. port for external Hi limit | 25. Return temperature sensor |
| 3. Flow-connection | 26. Boiler block temperature sensor |
| 4. Not available | 27. Frame |
| 5. Return-connection | 28. Steering castor |
| 6. Filling/drain cock | 29. Fan |
| 7. Condensate collector | 30. Venturi |
| 8. Flue gas temperature sensor | 31. Gas valve multiblock |
| 9. Condensate drain | 32. Non return valve |
| 10. Measuring point (O ₂ , CO ₂ , CO) | 33. Gas filter |
| 11. Positioning wheels | 34. Air pressure differential sensor (LDS) |
| 12. Jacking bolts | 35. Air box |
| 13. Condensate drain hose | 36. Instrument panel |
| 14. Flue gas discharge | 37. Control Keys |
| 15. Inspection hatch | 38. Read-out window |
| 16. Not available, 10" vent ø system only | 39. Weather compensator (optional) |
| 17. Heat exchanger | 40. On/Off switch |
| 18. Flow temperature sensor | |
| 19. Air supply | |
| 20. Not available, 10" vent ø system only | |
| 21. Air supply grille | |
| 22. Gas connection | |
| 23. Inspection glass | |
- Other items see parts view section 15.5:
- a. Firing valve (3026)
 - b. Vent safety switch (3046)
 - c. Inlet gas adapter 2" NPT (3045)
 - d. Safety relief valve, see chapter 7.4.4.

- e. Flue gas damper (optional for Gas 310 boiler, standard for Gas 610 boiler)

3.2 OPERATING PRINCIPLE

Combustion air is drawn into the inlet connection from the plant room (room ventilated version) or from outside via the eccentric flue system (room sealed) by an air supply fan.

On the inlet side of the fan is a specially designed chamber (venturi unit) which takes gas from the multi-block and mixes it in the correct proportions with the incoming air. This mixing system ensures that the correct gas/air ratio is delivered to the pre-mix burner at all times.

Depending on demand (under the dictates of flow/return sensor and other external/internal control inputs) the 'abc®' system determines the required boiler output. The 'abc®' control then varies the speed of the air supply fan which alters the volume of air being drawn into the venturi, this change in volume is measured using air pressure differential which directly controls the volume of gas also being delivered to the venturi. The resultant controlled mixture is delivered to the premix burner.

This mixture is initially ignited by the combined ignition/ionization probe which monitors the state of the flame. Should the flame be unstable or not ignite within the pre-set safety time cycle the controls will (after 5 attempts) shut the boiler down requiring manual intervention to reset the boiler. The digital display will indicate a flashing fault code confirming the reason for the failure.

The products of combustion in the form of hot flue gases are forced through the heat exchanger transferring their heat to the system water, (the flue gas temperature is reduced to approximately 9-14° F [5-8° C] above the temperature of the system return water) then discharged via the condensate collector, to the flue gas outlet connection, to atmosphere.

Because of the low flue gas exit temperature there will be a vapor cloud formed at the flue gas terminal – this is not smoke -, simply water vapor formed during the combustion process.

If the flue gas temperature falls below dew point 131°F [55°C], water vapor (created during the combustion process) will begin to condense out in the boiler, transferring its latent heat into the system water, thereby increasing the output of the boiler with-out increasing the gas consumption.

Condensation formed within the boiler and flue system is discharged from the boiler to an external drain via the drain pan and siphon supplied.

4 TECHNICAL DATA

4.1 Dimensions

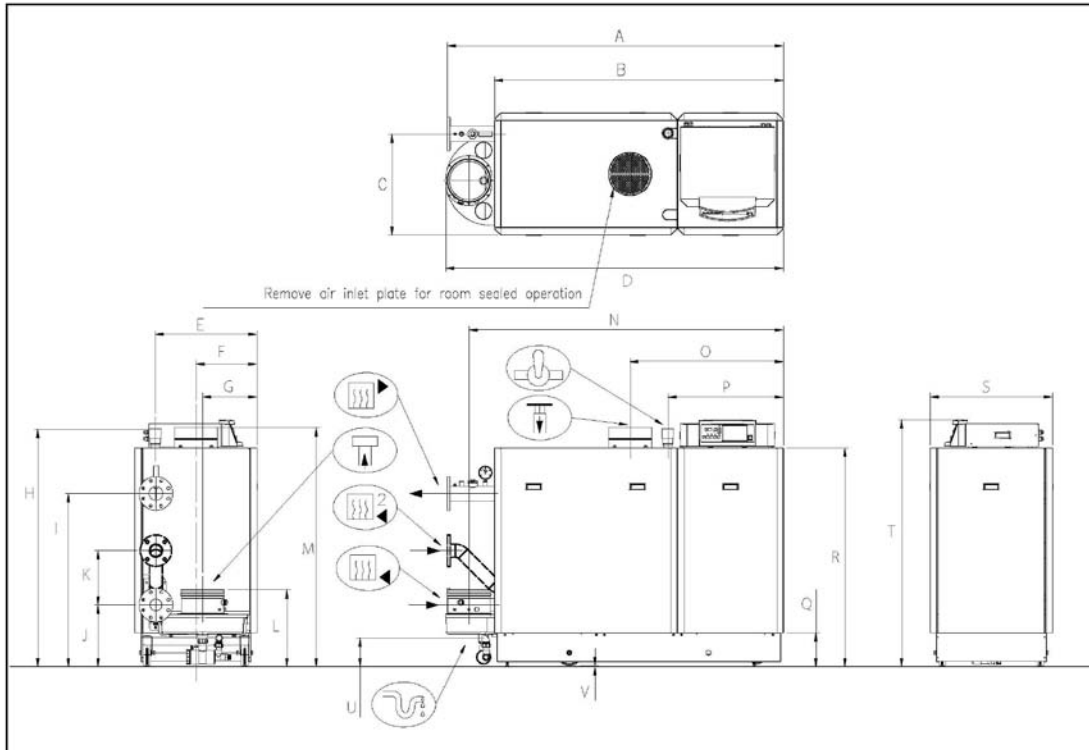

fig. 03 Elevation drawings

- Flow connection 3 inch ANSI 150# flange
- Return connection 2.5 inch
- Gas connection 2 inch NPT (BSP to NPT adapter provided)
- Condensate drain 1 1/4 inch
- Flue gas discharge 10 inch (starter piece may be required, consult vent manufacturer)
- Combustion air supply 10 inch (starter piece may be required, consult vent manufacturer)

Dimensions

Gas 310 ECO Model	A		B		D		N		O	
	mm	inch	mm	inch	mm	inch	mm	inch	mm	inch
310-5	1590	62 39/64	1312	51 21/32	1600	63	1463	57 39/64	1004	39 17/32
310-6	1590	62 39/64	1312	51 21/32	1600	63	1463	57 39/64	901	35 31/64
310-7	1980	45 61/64	1702	67	1990	78 11/32	1853	72 61/64	1110	43 45/64
310-8	1980	45 61/64	1702	67	1990	78 11/32	1853	72 61/64	1007	39 21/32
310-9	1980	45 61/64	1702	67	1990	78 11/32	1853	72 61/64	904	35 19/32

Unit	C	E	F	G	H	I	J	K	L	M
Inch	23 15/32	23 5/8	14 3/16	12 41/64	55 13/64	40 1/4	14 3/8	12 39/64	17 59/64	55 33/64
mm	596	600	360	321	1402	1022	365	320	455	1410

Unit	P	Q	R	S	T	U	V
Inch	26 25/32	7 7/8	50 51/64	28 23/64	57 3/8	6 45/64	21/64
mm	680	200	1290	720	1457	170	8

table 01, main dimensions, all fractions rounded up

4.2 GAS 610 ECO TECHNICAL DATA

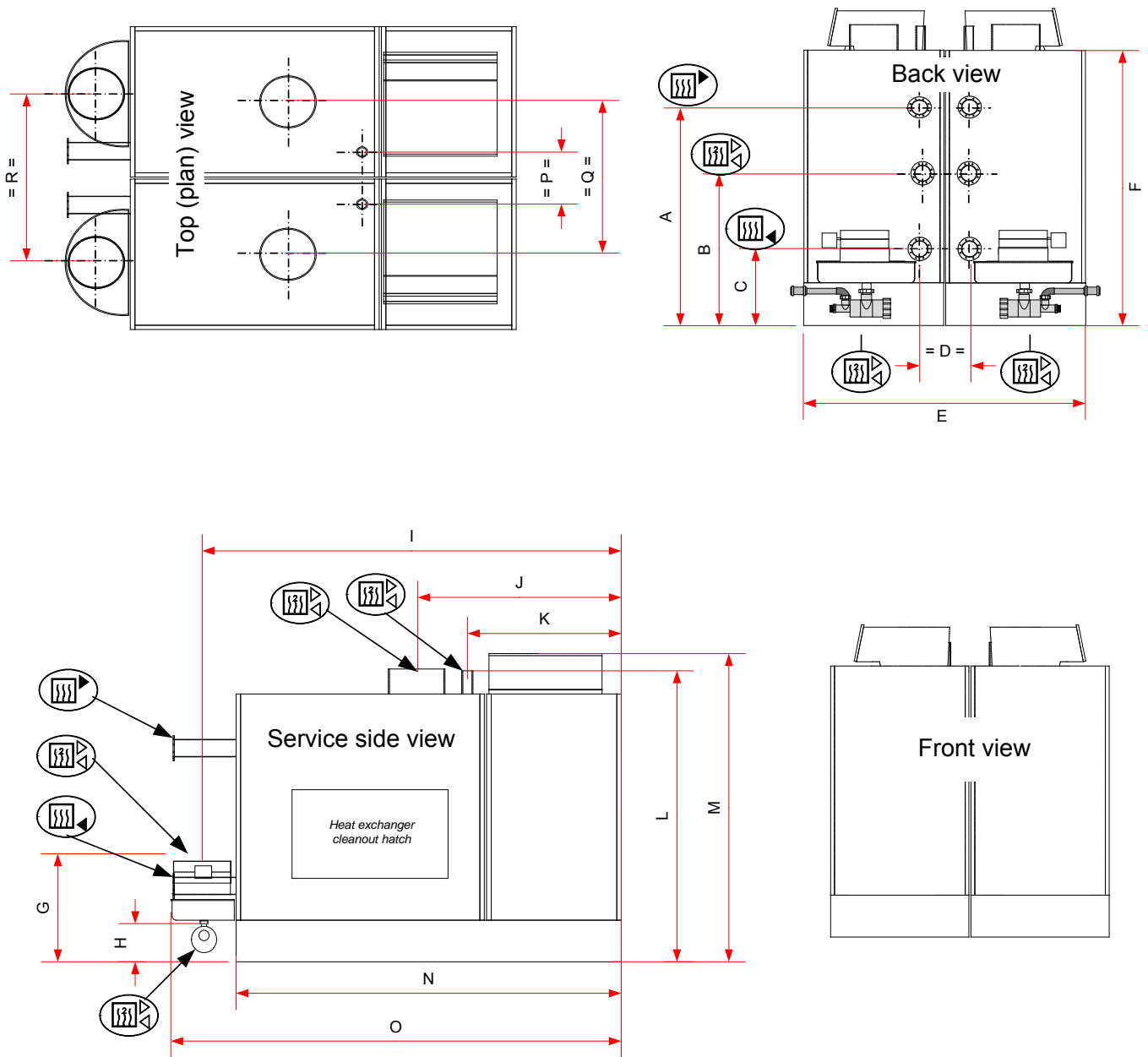

Gas 610 ECO Series MAIN DIMENSIONS												
Model	A		B		C		D		E		F	
	In.	mm	In.	mm	In.	mm	In.	mm	In.	mm	In.	mm
Gas610-6	40.5	1029	27	685	14.4	365	10.2	258	57.1	1450	50.8	1290
Gas610-7												
Gas610-8												
Gas610-9												

Model	G		H		I		J		K		L	
	In.	mm	In.	mm	In.	mm	In.	mm	In.	mm	In.	mm
Gas610-6	22.2	564	6.7	170	57.6	1463	35.5	901	26.8	680	55.2	1402
Gas610-7					43.7	1110						
Gas610-8					39.6	1007						
Gas610-9					35.6	904						

Model	M		N		O		P		Q		R	
	In.	mm	In.	mm	In.	mm	In.	mm	In.	mm	In.	mm
Gas610-6	57.4	1457	51.7	1312	63	1600	9.8	250	28.7	730	28.9	734
Gas610-7			67	1702	78.3	1990						
Gas610-8												
Gas610-9												

Gas 610 ECO Series Service & Combustible Clearances (MIN)					
A*		B		C	
In.	mm	In.	mm	In.	mm
12	300	12	300	31.5	800

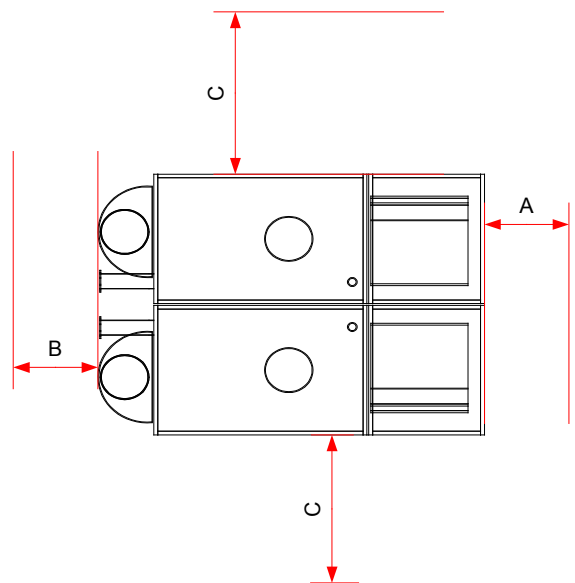

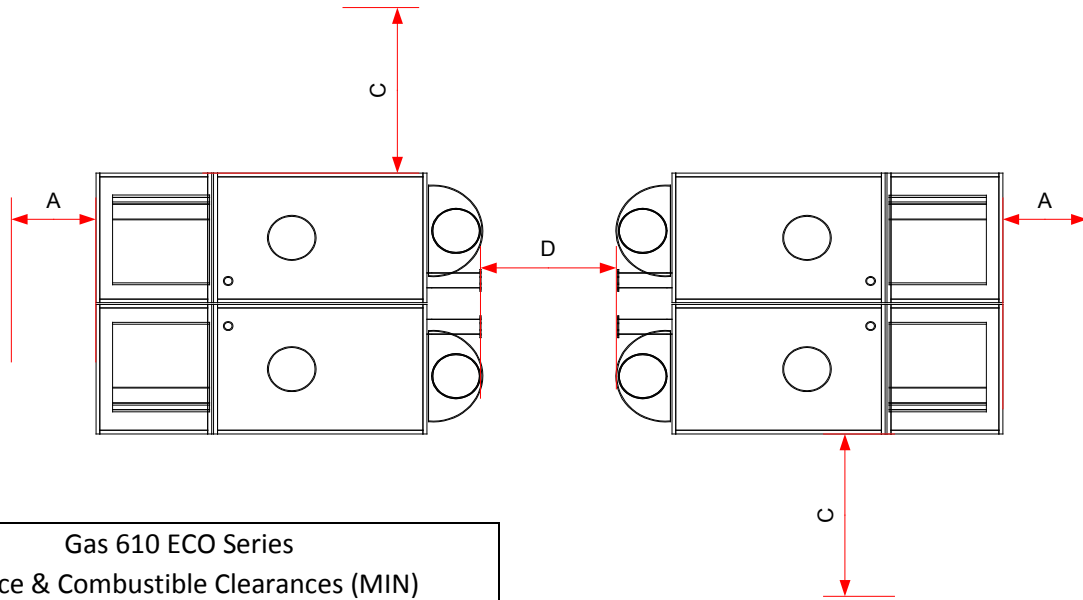

Gas 610 ECO Series Service & Combustible Clearances (MIN)							
A*		B		C		D	
In.	mm	In.	mm	In.	mm	In.	mm
12	300	12	300	31.5	800	24	600

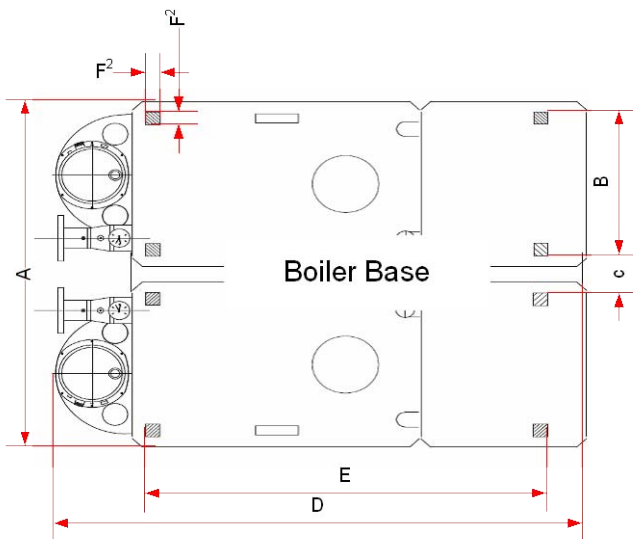

Gas 610 ECO Series Base & leveling legs dimensions													
Model	A		B		C		D		E		F ² (Square)		
	In.	mm	In.	mm	In.	mm	In.	mm	In.	mm	In.	mm	
Gas610-6	57.08	1450	24.8	630	4.1	104	1590	62.6	44	1118	2.16	55	
Gas610-7							1980	78	59.4	1508			
Gas610-8													
Gas610-9													

Boiler Model	Unit	De Dietrich Gas 310 ECO				
		310-5	310-6	310-7	310-8	310-9
General						
Firing Sequence Operation		On-Off, 2 Stage or Fully Modulating				
Minimum Fuel Input	MBH [kW]	205 [60]	256 [75]	311 [91]	358 [105]	413 [121]
Maximum Fuel Input	MBH [kW]	1,017 [298]	1,269 [372]	1,529 [448]	1,785 [523]	2,041 [598]
Minimum Heat Output	MBH [kW]	191 [56]	242 [71]	287 [84]	334 [98]	386 [113]
Maximum Heat Output	MBH [kW]	962 [282]	1,205 [353]	1,457 [427]	1,703 [499]	1,955 [573]
Efficiency						
Combustion [Gross]	%	CSA Certified Avg. 97.4 – (potential up to \cong 99.9%)				
Thermal Efficiency [Net]	%	95.3 – (potential up to \cong 99.9%)				
Standby Losses [Average]	%	< 0.3				
Gas & Venting						
Gas Type	Type	Natural Gas Only				
Gas Inlet Connection Size	BSP Inch	2 inch BSP - Adapter Required 2" M-BSP to 2" M-NPT				
Gas Inlet Pressure Range	In. w.c. [mbar]	3.5 - 14/8.5 - 35				
NO _x emissions [O ₂ = 0%]	ppm	< 35				
Residual Fan Duty	In. w.c. [mbar]	0.60 [1.50]				
<i>Available In: Room air vertical or horizontal venting - Sealed combustion horizontal or vertical venting arrangements</i>						
Flue-Gas Vent Diameter	Inch	10				
Combustion Air Vent Diameter	Inch	10				
Flue-Gas Mass Range	lb/h [kg/h]	201-999 [91-453]	251-1,246 [114-565]	304-1,499 [138-680]	353-1,748 [160-793]	403-2,000 [183-907]
Flue gas temperature at 104/86 ^o F	^o F [^o C]	126/52				
Condensate Drain Connection	inch	1.25				
Water						
Heating Return	inch	2.5				
Heating Supply	inch	3.0				
Maximum Water Temp. Safety Limit	^o F [^o C]	200/93				
Water Temperature Operating Range	^o F [^o C]	68 - 194 [20 - 90]				
Water Pressure Range	psig [barg]	11.6 - 100 [0.8 - 6.89] ASME MAWP 100				
Boiler Water Content [Liters]	Gallons	12.9 [49]	15.9 [60]	18.8 [71]	21.7 [82]	24.6 [93]
Water Resistance @ 20 ^o F Δ T [11 ^o C Δ T mbar]	Ft. H ₂ O [mbar]	12.5 [374]	12.2 [364]	13.3 [397]	12.2 [364]	13.8 [413]
Water Resistance @ 36 ^o F Δ T [20 ^o C Δ T mbar]	Ft. H ₂ O [mbar]	3.78 [113]	3.68 [110]	4.01 [120]	3.68 [110]	4.18 [125]
Electrical						
Main Supply	V/P/H	120/60/1 - 15A maximum				
Power Consumption	watt	24 - 370	24 - 380	24 - 470	24 - 610	24 - 840
IP-IEC-NEMA Protection	Rating	IP 20 [NEMA Type 1]				
Other						
Gas Vent Category	Types	ANSI Z21.13/CSA 4.9 Gas Vent Category II or IV - Special Venting Type BH Only				
Combustion Air Temperature	^o F [^o C]	-4 to 104 [-20 to 40]				
Installation Altitude	Ft. [m]	4,500 [1,370m]				
Dry Boiler Weight	lb [kg]	794 [360]	904 [410]	1,014 [460]	1,124 [510]	1,235 [560]
Floor Area	Ft ² [m ²]	12.9 [1.2]		15.1 [1.4]		
Noise Level @ 1m [Average]	dB(A)	60				

Boiler Model	Unit				
		610-6 [2 x 6 Section]	610-7 [2 x 7 Section]	610-8 [2 x 8 Section]	610-9 [2 x 9 Section]
General					
Firing Sequence Operation		2 or 4 Stage or Fully Modulating			
Minimum Fuel Input	MBH [kW]	345 [101]	485 [142]	481 [141]	580 [170]
Maximum Fuel Input	MBH [kW]	2,539 [744]	3,058 [896]	3,569 [1046]	4,081 [1196]
Minimum Heat Output	MBH [kW]	321 [94]	447 [131]	444 [130]	532 [156]
Maximum Heat Output	MBH [kW]	2,409 [706]	2,914 [854]	3,406 [998]	3,911 [1146]
Efficiency					
Combustion [Gross]	%	CSA Certified Avg. 97.4 – (potential up to \cong 99.9%)			
Thermal Efficiency [Net]	%	95.3 – (potential up to \cong 99.9%)			
Standby Losses [Average]	%	< 0.3			
Gas & Venting					
Gas Type	Type				
Gas Inlet Connection Size	BSP Inch	2 inch BSP - Adapter required 2" M-BSP x 2" M-NPT			
Gas Inlet Pressure Range	In. w.c. [mbar]	3.5-14/8.5-35			
NO _x emissions [O ₂ = 0%]	ppm	< 35			
Residual Fan Duty	In. w.c. [mbar]	0.52 [1.30]			
<i>Available In: Room air vertical or horizontal venting - Sealed combustion horizontal or vertical venting arrangements</i>					
Common Flue-Gas Vent Diameter	Inch	14			
Combustion Air Vent Diameter*	Inch	2x 10 or 14 common			
Flue-Gas Mass Range	lb/h [kg/h]	337-2,491 [153-1130]	474-2,998 [215-1360]	472-3496 [214-1586]	567-3,999 [257-1814]
Flue gas temperature at 104/86°F	°F [°C]	126/52			
Condensate Drain Connection*	inch	1.25			
Water					
Heating Return*	inch	2.5			
Heating Supply*	inch	3.0			
Maximum Water Temp. Safety Limit*	°F [°C]	230 [110]			
Water Temperature Operating Range*	°F [°C]	68 - 194 [20 - 90]			
Water Pressure Range*	psig [barg]	11.6 - 100 [0.8 - 6.89] ASME MAWP = 100			
Boiler Water Content	US Gal [L]	31.8 [120]	37.6 [142]	43.4 [164]	49.2 [186]
Water Resistance @ 20°F ΔT [11°C ΔT mbar]*	Ft. H ₂ O [mbar]	12.2 [364]	13.3 [397]	12.2 [364]	13.8 [413]
Water Resistance @ 36°F ΔT [20°C ΔT mbar]*	Ft. H ₂ O [mbar]	3.68 [110]	4.01 [120]	3.68 [110]	4.18 [125]
Electrical					
Main Supply*	V/P/H	120/60/1 - 15A maximum - must be earth grounded			
Power Consumption*	watt	24 - 380	24 - 470	24 - 610	24 - 840
IP-IEC-NEMA Protection*	Rating	IP 20 [NEMA Type 1]			
Other					
Gas Vent Category	Types	ANSI Z21/CSA 4.9 Gas Vent Category II or IV - Special Venting Type 'BH'			
Combustion Air Temperature*	°F [°C]	-4 to 104 [-20 to 40]			
Installation Altitude	Ft. [m]	0 - 4,500 [0 - 1370] asl			
Dry Boiler Weight	lb [kg]	1,808 [820]	2,028 [920]	2,248 [1020]	2469 [1120]
Floor Area	Ft ² [m ²]	25.8 [2.4]		30.1 [2.8]	
Noise Level @ 1m [Average]*	dB(A)	60			
* Applies to each boiler module					

Table 02, Technical data

4.3 GAS 310 ECO QUOTATION SPECIFICATION:

- Fully assembled cast aluminum floor standing sectional hot water boiler.
- Premix burner with stainless steel cylinder with perforated holes for precise air-fuel mixture and velocity with a stainless tube with woven steel fiber for stable flame and heat insulation.
- Fully condensing boiler.
- ASME approved design, CRN for each Canadian Province.
- Precise air to fuel ratio through firing range with high turn down 5:1.
- Boiler comes complete with a digital combination flame safe guard and a boiler control, with comprehensive operating, service and fault diagnostic capabilities.
- Firing capabilities, ON-Off, 2-stage or fully modulating [0-10v].
- Capable of receiving BMS control.
- Local-remote control [enable/disable].
- Boiler control equipment communication socket for PC or PDA device used with OEM software for advanced service and trouble-shooting diagnostics.
- A = Control facing short side or (front)
- I = Service side (right or left hand execution)
- Available for conventional chimney with room or direct vent, CLV and sidewall vented venting systems.
- Fully factory pressure and fire tested.
- Distinctive powder coated enamel steel removable casing.
- Rigid steel boiler frame with castors for easy maneuvering into boiler's final position.
- Certified by CSA for USA and Canadian markets.
- High combustion and thermal efficiencies.
- No proven water flow requirements.
- No minimum temperature requirements.
- Manufactured in an ISO 9001 certified facility.
- Max 100 psi - System water operating pressure
- ASME safety relief valve
- Pressure & Temperature gauge
- Optional communication protocol gateway (LonWorks®, BACnet®, etc...)
- Lead/lag (cascade) system manager for up to 8 boilers, space heating pump, 2 mixing valve circuits, 2 mixing valve pumps, DHW pump.

4.4 Delivery & ordering options:

- Available in 5 models
- Left or right service side option
- 2 stage or modulating control
- Weather compensator control
- Condensate neutralization system with or without pump
- Multiple (Cascade) boiler control
- DHW production kit
- Vent damper [required for co-venting]
- Pressure transducer for system pressure
- Low & High gas pressure switch
- Gas valve proofing system
- Secondary (CSD-1 compliant) Low water cut-off control
- Safety relief valve according to system pressure
- Combustion air filter
- Cleaning tool

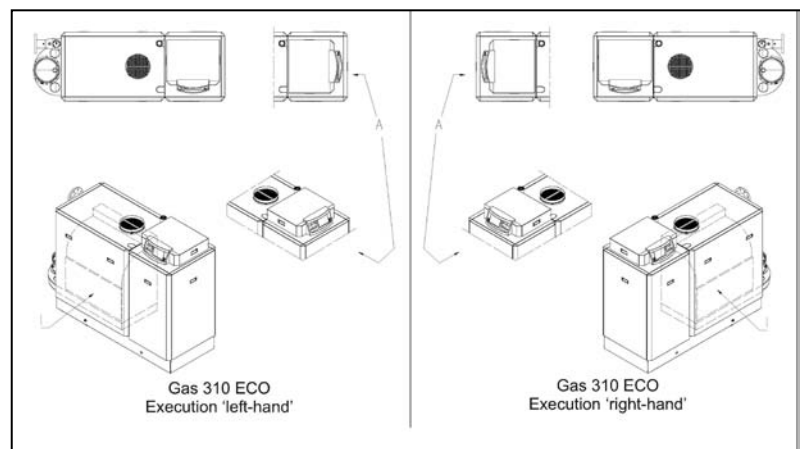

Consult factory DDR Americas Inc. [De Dietrich Boilers] for other available options, all orders must specify if optional controls are to be installed or shipped loose.

4.5 GAS 610 QUOTATION SPECIFICATION:

- Fully assembled cast aluminum floor standing sectional hot water boiler.
- Premix burner with stainless steel cylinder with perforated holes for precise air-fuel mixture and velocity with a stainless tube with woven steel fiber for stable flame and heat insulation.
- Fully condensing boiler.
- ASME approved design, CRN for each Canadian Province.
- Precise air to fuel ratio through firing range with high turn down 5:1 per unit.
- Boiler comes complete with a digital combination flame safe guard and a boiler control, with comprehensive operating, service and fault diagnostic capabilities.
- Firing capabilities, ON-Off, 2-stage or fully modulating [0-10v].
- Capable of BMS control.
- Local-remote control [enable/disable].
- Boiler control equipment communication socket for PC or PDA device used with OEM software for advanced service and trouble-shooting diagnostics.
- 2 control orientation versions, service or short end option.
-
- Available for conventional chimney, direct vent and sealed combustion venting systems.
- Fully factory pressure and fire tested.
- Distinctive powder coated enamel steel removable casing.
- Rigid steel boiler frame with castors for easy maneuvering into boiler's final position.
- Certified by CSA for USA and Canadian markets.
- High combustion and thermal efficiencies.
- No proven water flow requirements.
- No minimum temperature requirements.
- Manufactured in an ISO 9001 certified facility.
- Max 100 psi - System water operating pressure
- ASME safety relief valve (x2)
- Pressure & Temperature gauge (x2)
- Optional communication protocol gateway (LonWorks®, BACnet®, etc...)
- Lead/lag (cascade) system manager for up to 8 boilers, space heating pump, 2 mixing valve circuits, 2 mixing valve pumps, DHW pump.

4.6 Delivery & ordering options:

- Available in 4 models
- 2, 4 stage or modulating control
- Weather compensator control
- Condensate neutralization system with or without pump
- Multiple boiler control
- pressure switch
- Gas valve proofing system
- Low water cut-off control (CSD-1 compliant)
- Safety relief valve according to system pressure
- Combustion air filter
- Cleaning tool
- DHW production kit
- Standard vent damper
- Pressure transducer for system pressure
- Low gas pressure switch
- High gas pressure switch

Accessories must be ordered in pairs, one for each module.

Consult factory DDR Americas Inc. [De Dietrich Boilers] for other available options, all orders must specify if optional controls are to be installed or shipped loose.

5 EFFICIENCY INFORMATION

5.1 Combustion efficiency

- Theoretically efficiency up to 99.9% can be achieved with return water temperature of 104°F [40°C], the combustion efficiency according to ANSI Z21.13b-/CSA 4.9b-2007 average = 95.3%

5.2 Thermal efficiency [heat to water]

- Average thermal efficiency 97.4%

5.3 Standby losses

- Less than 0.3% with an average water temperature of 113°F [45°C]

6 APPLICATION DATA

The Gas 310/610 ECO can be used on all new and retrofit projects in both single and multiple configurations. Conventional and sealed combustion venting system capability means that the boiler can be sited almost any-where within a building.

External control systems (BMS) can be interfaced with the boiler to provide on/off – high/low or modulating (0-10 V dc input) firing control options.

7 INSTALLATION INSTRUCTIONS FOR HEATING INSTALLER

7.1 General

All gas appliances must, by law, be installed by competent person (Licensed gas-heating technician) It is in your own interest and that of safety to ensure that the law is complied with. The following codes must be adhered to when the De Dietrich Gas 310/610 ECO is installed:

- CSA B149 gas installation code & ANSI Z223.1 / NFPA 54 gas code.

In addition to the above regulations, this boiler must be installed in compliance with:

- National & local building codes
- ASME CSD-1 as required
- CSA & NEC electrical codes
- Other Regulations



Important:

The De Dietrich Gas 310/610 ECO is a CSA certified boiler and must not be modified or installed in any way contrary to these “Installation and maintenance Instructions.” Manufacturer’s Instructions must NOT be taken as overriding statutory obligations.

7.2 Delivery and installation

The De Dietrich Gas 310/610 ECO is supplied fully assembled, plastic wrapped and crated on a pallet. The overall dimensions of the crate are 31.5” [80cm] wide and 68.9” [175 cm] high with the length dependent on the number of sections (5 & 6 sections: 66.9” [170 cm], 7 to 9 sections: 82.3” [209 cm]). At the base of the packaging is a 30” [76 cm] wide pallet enabling it to be transported with a pallet truck, forklift truck or 4-wheel transport boards. Excluding the crate, the boiler is 28.4” [72cm] wide c/w casing panels and 27 5/8” [70 cm] without casing and will fit through most standard doors (minimum door opening width 31.5” [80 cm]. The boiler itself has wheels so that, once the packaging has been removed, it can easily be moved around on a smooth surface. The packaging lid includes a rocking ramp, which can be used to negotiate obstacles such as doorsteps and small plinths. Once in position the boiler is fixed into position using the fitted jacking bolts which both raise the wheels of the ground and level the boiler. Technical documentation is supplied in a holder on the inside of the boiler casing (beneath the instrument panel). A number of small loose components, such as the 4 support pads and the siphon for the boiler have been placed in the flue gas discharge.

The Gas 610 ECO boilers consist of a Gas 310-L and a Gas 310-R. Please refer to page 11 for details.

It is advisable (preferable) to install the Gas 310 ECO as follows:

- Place the crate c/w the boiler in the boiler room. Make sure there is enough room at one end of the crate for the boiler and ramp and clearance for the crate to be removed (at least 10ft [3M]).
- Place the 4 support pads under the adjustment bolts.
- Use the adjusting bolts to jack up the boiler – lifting it clear of the wheels and with the top of the condensate collector level.
- Fit the siphon assembly.
- Use the plastic packaging to protect the boiler until required for use.
- Service side dimension 'B', for servicing it is recommended that an additional 8 inches [200mm] be added, but is not absolutely required.
- If the control is orientated to the short end, dimension A will need to be increased by 19.5 inches [495mm].
- At least 16" [400mm] above the boiler

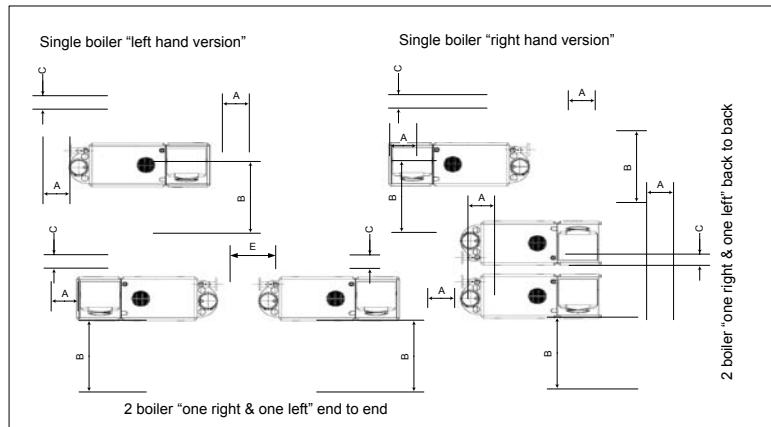

unit	A	B	C	D	E
inch	12	31.5	6	6	24
mm	300	800	150	150	600



Important!!

- Always transport the boiler in the protective packaging whenever possible.
- Remove fixing strips, packaging lid and all other packaging, leaving the boiler on the pallet.
- Place the packaging lid on the end of the pallet, creating a ramp – secure with screws.
- Roll the boiler, on its wheels, off the pallet and down the ramp to the boiler room floor.



WARNING!

Use retaining straps to control the rate of travel – Do Not stand in front of the boiler!

- Maneuver the boiler to required final position.

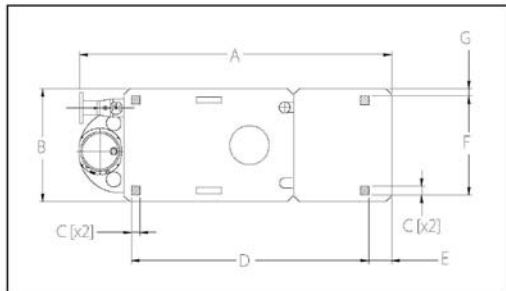

The pallet lid can be used as a rocking ramp to convey the boiler over obstacles, such as thresholds, etc.



Important!!

The wheels are designed for transport purposes only and MUST NOT be used when the boiler is in its final position!



Important!!

Additional protection may be required if site conditions warrant it – overhead builders working, insulation, etc.



Important: Do not install boiler on carpet or other combustible materials. Never stand on the boiler. The boiler casing is not designed for excessive force or weight.

Boiler base dimensions

Boiler Model	A		B		C		D		E		F		G	
	inch	Mm	inch	mm	inch	mm	inch	mm	inch	mm	inch	mm	inch	mm
310-5	62	1590	28 23/64	720	2 11/64	55	44	1118	5 23/32	145	24 13/16	630	1 25/32	45
310-6	39/64						1/64							
310-7	45	1980					59 3/8	1508						
310-8	61/64													
310-9														

table 03[b] - base - foundation dimensions

It is advisable (preferable) to install the Gas 610 ECO as follows:

Place the crate c/w the boiler in the boiler room. Make sure there is enough room at one end of the crate for the boiler and ramp and clearance for the crate to be removed (at least 10ft [3M]).

- Place the 4 support pads under the adjustment bolts.
- Use the adjusting bolts to jack up the boiler – lifting it clear of the wheels and with the top of the condensate collector level.
- Fit the siphon assembly.
- Use the plastic packaging to protect the boiler until required for use.
- Service side dimension 'B', for servicing it is recommended that an additional 8 inches [200mm] be added, but is not absolutely required.
- If the control is orientated to the short end, dimension A will need to be increased by 19.5 inches [495mm].



IMPORTANT!

Always transport the boiler in the protective packaging whenever possible.

Remove fixing strips, packaging lid and all other packaging, leaving the boiler on the pallet.

Place the packaging lid on the end of the pallet, creating a ramp – secure with screws.

Roll the boiler, on its wheels, off the pallet and down the ramp to the boiler room floor.



WARNING!

Use retaining straps to control the rate of travel – Do Not stand in front of the boiler!

Maneuver the boiler to required final position.



The pallet lid can be used as a rocking ramp to convey the boiler over obstacles, such as thresholds, etc.



IMPORTANT!! The wheels are designed for transport purposes only and **MUST NOT** be used when the boiler is in its final position!



IMPORTANT!! Additional protection may be required if site conditions warrant it – overhead builders working, etc.



IMPORTANT!! Do not install boiler on carpet or other combustible materials.

Never stand on the boiler the boiler casing is not designed for excessive force.

7.3 Flue gas discharge and air supply Venting

7.3.1 General

The Gas 310/610 ECO is suitable for both conventional room-supplied or direct vent (sealed combustion air) applications. All vent terminals should comply with the local and national codes. Any horizontal pipe-work in the flue gas discharge system should slope towards the boiler. Horizontal pipe-work in the air supply system should slope towards the supply opening and may require a drain point at the low point. Care should be taken when locating the flue exit points as a vapor plume will be visible when the boiler is operational (flue gas temperature can be less than 170°F [75°C] resulting in the water vapor condensing upon contact with the air).

7.3.2 Boiler Venting Types

Flue gas venting material: Use only an approved gas vent category II and IV type “BH” Made of AL29-4C® or SS316 as approved. Do not use PVC-CPVC plastic vent systems.

7.3.3 Venting options

The standard delivery of the De Dietrich Gas 310/610 ECO boiler can be installed with any of the venting options listed above. See each respective section for details.

7.3.4 Vent Termination Inlet/Outlets

The vent terminals must be installed to provide suitable protection against wind, rain, snow or blockage along with a rodent/debris screen. See section 7.3.6 & 7 for other requirements. Conventional chimney application tapered (finishing) cone, and sidewall or direct vent applications require a termination TEE or 90° Elbow fitting.

Warning:

The flue gas vent pipe must be airtight and watertight. Horizontal sections of the venting must slope downward towards the boiler 1/2” per linear foot [12mm] and adequate vent support must be provided.

7.3.5 Combustion Air Supply Requirements

 The boiler requires a clean, fresh and adequate supply of combustion air, failure to provide sufficient combustion air supply will result in carbon monoxide (CO) production that could lead to personal injury including loss of life or damage to boiler or property. Do not store

any flammable liquids, fluids, vapors or materials near the vicinity of the boiler.

Special attention:

- Quality of combustion air
- Dust, fumes, corrosive elements, hydrocarbons, other unknown containments
- Paint, beauty, automotive etc. shops

Room combustion air supply requirements:

The boiler must be provided with an adequate combustion air supply, the combustion air supply requirements must be determined and sized in accordance to national and local codes having jurisdiction. CSA B149 & ANSI Z223.1 – More than one combustion air source may be required. An optional filter should be fitted air intake housing.

Air supply venting materials:

Aluminum, galvanized or stainless steel material, do not used flexible/corrugated materials.

Air supply structure:

The air supply pipe must also be airtight. Horizontal sections in the air supply must slope away from the boiler towards the supply opening and incorporate a drain connection if the route rises from a lower point. It is necessary to provide an easily removable air vent for maintenance reasons from the boiler air intake connection.

Conventional Chimney Applications: (Section 7.3.6)

A vertical chimney-vent system with either room or direct vent supplied (sealed combustion) air supply.

CLV – Sealed Combustion Systems Applications: (Section 7.3.6)

A vertical chimney vent system with direct vent combustion air supply (sealed combustion), operating at two different pressure zones or vent terminal locations.

Sidewall Vented Applications: (Section 7.3.7)

A horizontal venting system for the exhaust and air intake, the flue gases and combustion air terminated at same elevation and pressure level, can be either room supplied combustion air or direct vented (sealed combustion)

7.3.6 Conventional Chimney & CLV Systems Application Requirements:

⚠ Warning:

The boiler should never be operated in a negative building pressure. Caution should be exercised with exhaust fans, air handling & other devices, that could affect the buildings air pressure or combustion air supply. All venting must be arranged to avoid and prevent the accumulation of flue gas condensation. An improperly sealed venting system could result in carbon monoxide poisoning; ensure adequate support and fastening of the system. Ensure venting can safely exhaust all flue gases to the outside in a safe and effective manner. Do not puncture or drill holes in any portion of the venting, the boiler is equipped with a pressure and emission test port. Venting lengths values must be between equivalent lengths show in table 04a-b. Any horizontal runs of the venting must slope towards the boiler 1/2" per linear foot. The length in the tables apply to each vent length separately (air intake and flue gas exhaust)

Exterior Venting:

Any portion of the venting exposed the outside climate shall be suitable for exterior applications.

Conventional Chimney applications:

This venting system uses a single vent to discharge all flue gases to the outside vertically, combustion air provided with the boiler room, the air source must be sized in accordance to national codes CSA B149 & ANSI Z223.1 or local codes having jurisdiction, more than one source may be required.

Conventional Chimney with direct vent (sealed combustion air) applications:

This venting system uses either a co-axle or single vent for both the air intake and the flue gas exhaust; the boiler room does not require a combustion air source, as all air for combustion is taken from the outside source.

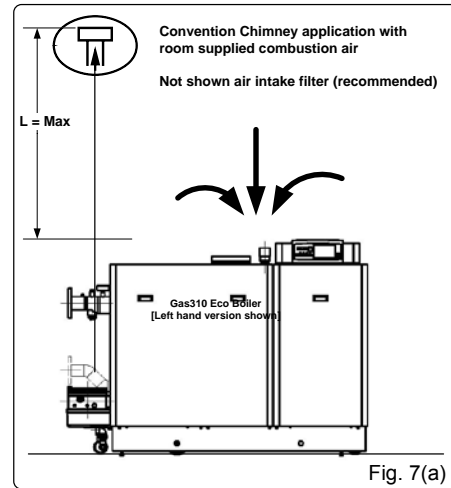

Chimney Application [room supplied combustion air]

Gas 310/610 Model	Vent ø		Vent Length [Min]		Vent Length [Max]		90° Elbow = Length		45° Elbow = Length	
	inch	mm	Ft.	m	Ft.	m	Ft.	m	Ft.	m
	310-5	10	250	5	1.5	250	76	12	3.5	6.5
310/610-6										
310/610-7										
310/610-8										
310/610-9										

Table 04[a] - venting length chart. Table also applies to Gas 610 models.

Chimney application with direct vent (sealed combustion air)

Gas 310/610 Model	Vent ø		Vent Length [Min]		Vent Length [Max]		90° Elbow = Length		45° Elbow = Length	
	inc h	mm	Ft.	m	Ft.	m	Ft.	m	Ft.	m
	310-5	10	250	5	1.5	200	60	12	3.5	6.5
310/610-6										
310/610-7										
310/610-8										
310/610-9										

Table 04[b] - venting length chart. Table also applies to Gas 610 models.

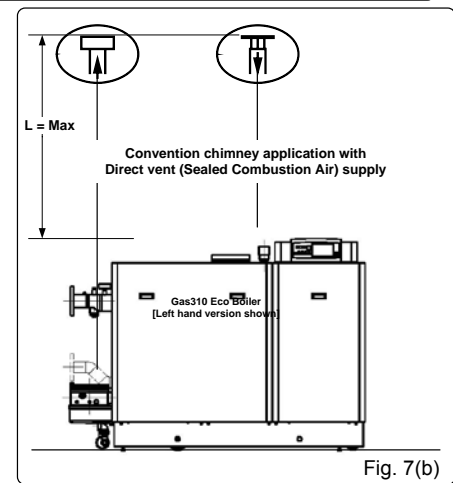

Note: All lengths shown in table 04a-b are for a single boiler only. For multiple boilers (cascade) common venting systems consult DDR Americas Inc. for assistance.

7.3.6 Continued

CLV system application (Different Pressure Zones)

This venting system uses two separate vents that terminate at different points of the building (2 different pressure zones), a vent for combustion air and another for the flue gases. All combustion air is from the outdoor source. The vent terminal shall discharge flue gases away from the building structure so that the flue gases do not cause damage to the building. The vent terminal locations follow local and national codes requirements. [See section 7.3.9]

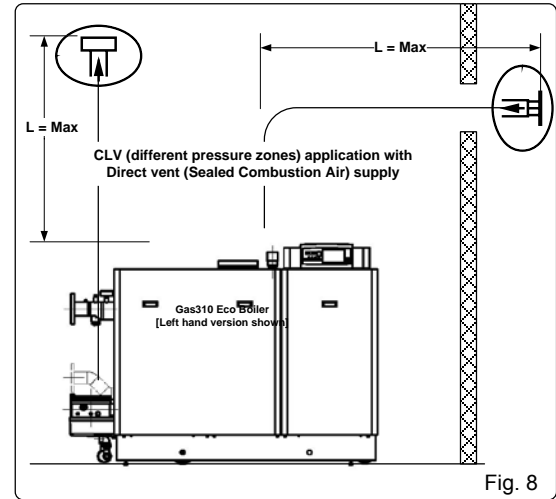

Fig. 8

CLV vent systems venting length chart

Gas 310/610 Model	Vent ø		Vent Length [Min]		Vent Length [Max]		90° Elbow = Length		45° Elbow = Length	
	inch	mm	Ft.	m	Ft.	m	Ft.	m	Ft.	mm
310-5	10	250	5	1.5	180	54	12	3.5	6.5	2
310/610-6										
310/610-7										
310/610-8										
310/610-9										

Table 04[c] - venting length chart.
Table also applies to Gas 610 models.

7.3.7 Sidewall vented application with or without direct vent (sealed combustion air):

⚠ Caution – Warning:

Flue gas condensation is very aggressive and corrosive which could lead to failure of the venting system or drains, consult local and national codes regarding flue gas condensation disposal. The P-trap assembly must be properly filled with water to avoid escape of the flue gas emissions. The flue gas condensation may require neutralization prior to entering the drain.

⚠ Warning:

An improperly sealed venting system could result in carbon monoxide poisoning; ensure adequate support and fastening of the system. Ensure venting can safely exhaust all flue gases to the outside in a safe and effective manner. Do not puncture or drill holes in any portion of the venting, the boiler is equipped with a pressure and emission test port. All venting must be arranged to avoid and prevent the accumulation of flue gas condensation.

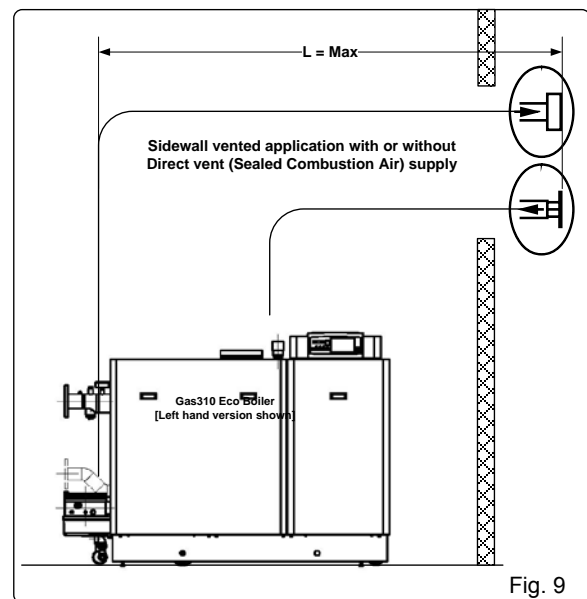

Fig. 9

⚠ Warning & precautions:

Venting lengths must not exceed the minimum and maximum equivalent lengths shown in table 07. Any horizontal runs of the venting must slope towards the boiler 1/2" per linear foot.

This venting system uses a single vent to discharge all flue gases to the outside, combustion air provided within the boiler room, the air source must be sized in accordance to national codes CSA B149 & ANSI Z223.1 or local codes having jurisdiction, more than one source may be required. The vent terminal locations follow local and national codes requirements. The vent terminal shall discharge flue gases away from the building structure so that the flue gases do not cause damage to the building, the vent terminal locations must also follow CSA B149 & ANSI Z223.1.[See section 7.3.9

Application Note:

The venting must be between the minimum and maximum equivalent vent lengths show in table 5. For values not show in the chart, consult your local De Dietrich Representative.

Gas 310/610 Model	Vent \varnothing		Vent Length [Min]		Vent Length [Max]		90° Elbow = Length		45° Elbow = Length	
	inch	mm	Ft.	m	Ft.	m	Ft.	m	Ft.	mm
310-5	10	250	5	1.5	65	20	12	3.5	6.5	2
310/610-6										
310/610-7										
310/610-8										
310/610-9										

Table 05 - venting length chart. Table also applies to Gas 610 models.

⚠ Caution – Warning:

Flue gas condensation is very aggressive and corrosive which could lead to failure of the venting system or drains, consult local and national codes regarding flue gas condensation disposal. The P-trap assembly must be properly filled with water to avoid escape of flue gas emissions. The flue gas condensation may require neutralization prior to entering the drain.

7.3.8 Co-venting – Retrofitting:

At the time of removal of any existing boiler is removed from a common vent system, the following steps shall be performed with the each remaining appliance connected to the common vent in operation and not in operation. This boiler must not be co-vented with a category I or III appliance. The boiler must have a vent damper installed when in a vent category IV positive pressure installation co-venting with other appliances.

- Any used opening of the vent system be properly sealed
- Visually inspect the venting system for proper size and horizontal pitch, determine there is no blockage, restriction, leakage, corrosion and other deficiencies could cause an unsafe condition.
- Close all building doors, windows and all doors between the appliances which remain connected to the common venting system are located and other space of the building. Turn on clothes dryers, exhaust fan at maximum speed and any appliance not connected to the common vent system, close fireplace dampers. Do not operate a summer exhaust fan.
- Place in operation each of the appliances installed in the common vent system being inspected. Follow the lighting instructions. Adjust thermostat so appliance will operate continuously.
- Test for spillage near and around the each of the gas appliances after 5 minutes of main burner operation.
- After determining that each appliance remaining connected to the common venting system properly vents when tested as outlined above, return all doors, windows, exhaust fan, fireplace dampers and any other gas burning appliance to their normal positions.
- Any improper operating of the venting system must be corrected so the installation conforms to either ANSI Z223.1/NFPA 54 or CAN/CSA B149.1 gas installation codes. When resizing any portion of the common venting system, the common venting system shall be resized to approach the minimum size as determined using the appropriate tables in Part II of ANSI Z223.1/NFPA 54 gas code &/or CAN/CSA B149.1 natural gas and propane installation code.

7.3.9 Vent terminations installation precautions:

[Consult national & local codes for other requirements]

All exhaust terminations for conventional chimney must be finished with a finishing cone with tapered end, with a bird/rodent screen. All sidewall, direct vent, CLV systems must be finished with either a 90° elbow TEE termination, the combustion air inlet must be a 90° and must be provided with a debris/bird-rodent screen. All terminals shall be arranged to avoid prevailing winds and prevent the accumulation of flue gas condensation.

⚠ Warning: In all installations avoid vent termination locations where excessive debris or snow could accumulate leading to blocking of the vent terminals or where prevailing winds and rain could enter the vent terminal creating additional resistance to the venting system.

Vent terminals should avoid being installed where the building exterior could be tarnished from the flue gases, a shield or another location should be considered.

The vent terminals shall be installed according to the instructions as provided terminals shall not be less than 2 inches [50mm] from the wall surface or more than 10 inches [254mm] from the ϕ of terminal to the wall. For high traffic locations, the vent terminal shall be guarded.

According to the national gas codes [CSA B149 & ANSI Z223.1/NFPA 54] a vent shall not terminate...

- Directly above a paved walkway or driveway which serves two or more buildings or where the flue gas condensation or vapor could create a hazard or improper operation of regulators, relief's or valves or any other device.
- Above or below any electric or gas meter, regulators & relief devices unless a 4ft [1.2m] horizontal clearance distance to be maintained.
- Less than 7ft [2.1m] above any paved sidewalk or driveway.
- Less than 6ft [1.8m] from any combustion air inlet source from any nearby building.
- Less than 4 ft [1.2m] above a meter/regulator assembly horizontally from a vertical centerline of the regulator vent outlet to a maximum vertical distance of 15ft [4.6m].
- Less than 1ft [0.3m] above grade or normal snow level in the area is expected.
- Less than 3ft [0.9m] from windows, doorways, and combustion air supplies nearby buildings or other appliances.
- Under a veranda, porch or deck, unless [1] the veranda, porch or deck is fully open on at least 2 sides underneath. [2] The distance between the top of the terminal and the grade is greater than 1ft [0.3m].

7.4 INSTALLATION DETAILS

7.4.1 Water pressure

The boiler is suitable for a maximum working pressure of 100 psi [6.8 bar], the system pressure shall be at least 12 psi [0.8 bar]

7.4.2 Condensate discharge

Discharge the condensate directly into a drain. Only use synthetic material for the connecting pipe-work because of the acidity of the condensate (pH 2-5) and allow a min. 1.2 inch per 3 ft. [30mm per meter fall], to ensure a good gravity siphon flow rate. Fill the siphon with clean water before firing the boiler. It is not advisable to discharge into an outside gutter because of the risk of freezing. Consult local codes.

7.4.3 Water treatment

The system should be filled with mains, cold water (this will usually have a pH of between 7 and 8). Pressurized installations with a boiler/system content ratio of 1:10 or less should not require water treatment, provided the following conditions apply:

1. The system is flushed thoroughly to remove all fluxes and debris and filled completely once.
2. Make up water is limited to 5% per annum.
3. The hardness of the water shall conform to the water quality document requirements



All scale deposits will reduce the efficiency of the boiler and should be prevented. However provided the above is complied with any scale produced will not be too detrimental to the boiler efficiency and will not reduce the anticipated life expectancy of the boiler.

7.4.4 Safety valve

A safety relief valve NB certified with V or HV symbol as supplied must be installed on the boiler supply piping without any obstructions. The relief must be not smaller than 3/4" and no larger than NPS 4"; the pressure shall not exceed 10% above the MAWP and must be of an automatic reset type. The valve opening must be routed away so that no injury to persons or damage to property will result. Consult local codes. When replacing this safety relief valve, the relief capacity must be > than the minimum relief capacity as listed on the rating plate.

7.4.5 Water Flow & Content Protection:

The boiler if installed above radiation [heating circuits below the boiler] or as required by local codes or authorities having jurisdiction must install a low water cut-off safety device.

The boiler has been approved and has found to be in compliance to the LWCO protection, provided the factory pre-set high limit and flow temperatures are not altered and the modulating controls are used and no minimum flow rate is required as the 'abc®' system will monitor these conditions and reduce the boiler output, finally shutting down until flow conditions improve. As a result, the boiler is virtually unaffected by low water flow. Although boiler flow and content protection is provided, does not safeguard the entire heating system, additional low water content and temperature safety controls maybe needed in certain jurisdictions.

7.4.6 Noise production

The average noise level measured at 3 ft. [1m] distance around the boiler is < 60 dBA at full output, avoiding the need for additional acoustic measures.

7.5 Multiple boiler installation

The Gas 310/610 ECO can be installed individually or in a multiple boiler installation. The narrow width and depth of the boiler and its ability to be mounted closely together provides a high output within a small floor area.

7.6 Typical water system layout

- The piping diagram illustrates the minimum boiler system controls needed, the by-pass system is not necessary, but can be used in multiple heating temperature circuits.
- Consult all national, local and building codes having jurisdiction for other requirements regarding the boiler system.
- It is strongly suggested a decoupling device is used when the system flow is unknown. For multiple boilers, consult the factory.
- Check local codes regarding condensate discharge into the common drain.
- Water must be analyzed to ensure acceptable quality. If make water consumption is unknown, the system should be checked at regular intervals – consult water specialists for assistance. See section 7.4.3.
- When the boiler is connected to a refrigeration system, it must be installed so the chilled medium is piped in parallel with the boiler with appropriate valve to prevent the chilled medium from entering the boiler.
- The boiler piping system of a hot water boiler connected to heating coils located in air handling units where they may be exposed to refrigeration air circulation must be equipped with flow controls valves or other automatic means to prevent gravity circulation of the boiler water during cooling operations.

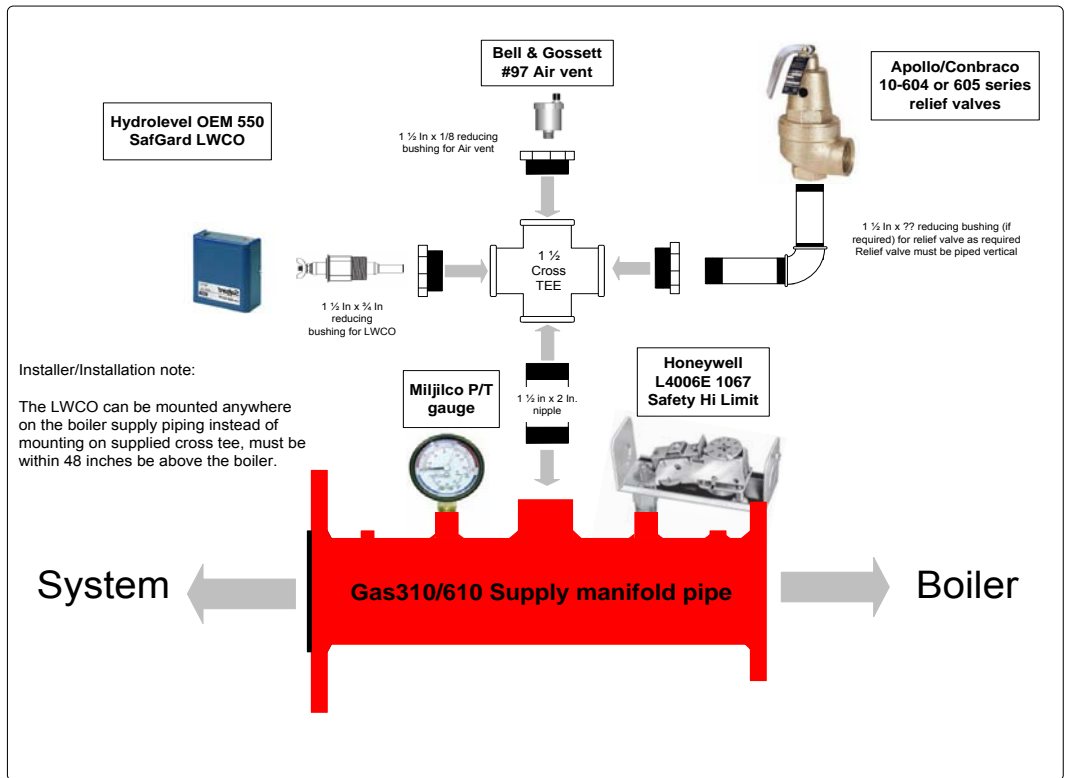
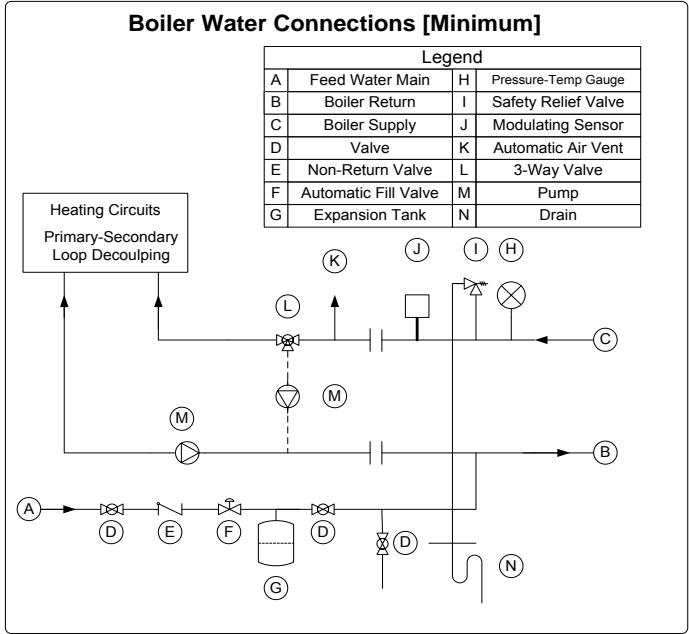

⚠ All water piping and reliefs shall be piped to avoid any ingest of water near the boiler controls. The piping diagram shown below does not reflect all systems consult local and national codes having jurisdictions regarding other water system controls required.



8 INSTALLATION INSTRUCTIONS FOR ELECTRICAL INSTALLER

8.1 General

The De Dietrich Gas 310/610 ECO is supplied as standard with electronic operating and flame ionization safety controls with a specially designed microprocessor at the heart of the system.



The boiler is pre-wired as shown in the wiring diagram in fig. 18. All external connections can be made on the terminal strips (one low voltage 24V AC and one main power voltage 120V AC).

Each boiler must be fused protected for a single phase power source 120/1/60 @ 15A, the circuit must be earth grounded and provided with a service switch that is within hand reach.

  Warning – Electrical shock hazard, can cause personal injury or loss of life, including property damage. – All electrical wiring to the boiler and controls must be protected from ingest of water and be properly grounded and bonded according to CEC Part I CSA 22.1 & NEC NFPA 70.

8.2 Electrical specifications

8.2.1 Main power voltage

Each boiler requires a 120V – 1 – 60 Hz supply rated at 10 amps with line/neutral/earth. The boiler is sensitive to line/neutral and therefore has a facility to ensure that line and neutral are correctly connected. If line and neutral are crossed, the display will flash  /  alternately.

8.2.2 Control unit

Manufacturer : Honeywell
 Type : MCBA 1458 D
 Main voltage : 120V 60 Hz
 Safety time : 3 sec.

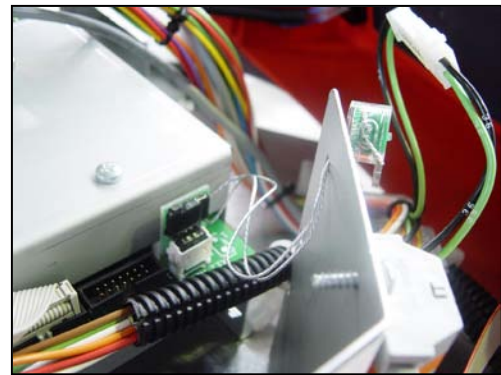

Fig. 13 Position code-key

Each De Dietrich Gas 310/610 ECO has a unique “boiler code.” These codes, together with other data as to boiler type, counter data, etc., are stored in a “code-key” that belongs to the boiler. If the control unit is replaced this information remains stored in the code-key.

8.2.3 Power consumption

Power consumption at stand-by / part load / full per boiler unit:

310-5: 12 Watt / 53 Watt / 370 Watt
 310-6: 12 Watt / 56 Watt / 380 Watt
 310-7: 12 Watt / 45 Watt / 470 Watt
 310-8: 12 Watt / 45 Watt / 610 Watt
 310-9: 12 Watt / 80 Watt / 840 Watt

Max boiler module start current 4 amps excluding a “system pump” if connected to terminal block X27 connections 9 and 10

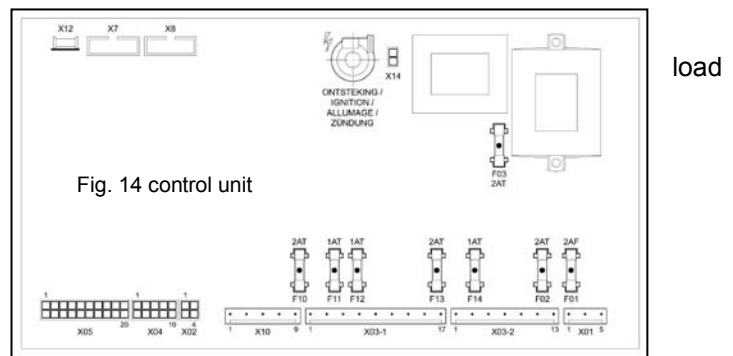

8.2.4 Fuse ratings

Fuses on the circuit board on the control unit:

F1 – 2 AF mains voltage fuse (automatic fuse)

F2 – 2 AT for gas valve multiblock

F3 – 2 AT for 24 V circuit

F10 – 2 AT for shunt pump

F11 – 1 AT for flue gas damper

F12 – 1 AT for butterfly valve

F13 – 2 AT for heating pump

F14 – 1 AT for external gas valve

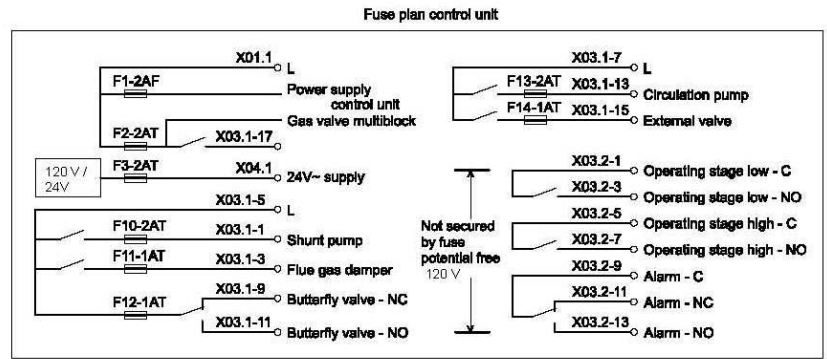
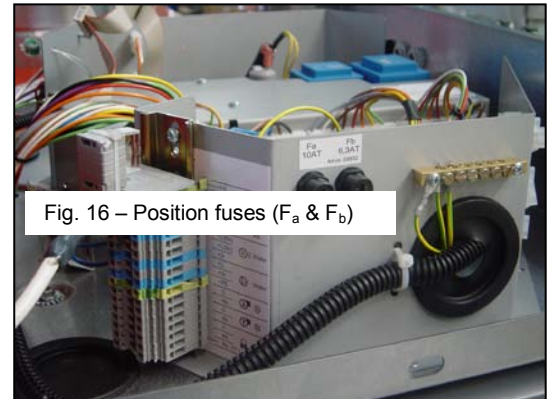

Fig. 15 – Fuse plan

The boiler fuse F_a is located behind / next to the 120V terminal strip. This fuse de-energizes the whole boiler and has a rating of 10 AT. The fan has a Power Factor Control (PFC ensures the main power supply is distributed more uniformly) and is fused with a 12 AT fuse F_b (behind / next to the 120 V terminal strip).



8.2.5 Temperature control

The De Dietrich Gas 310/610 ECO is equipped with an electronic temperature limit control based on flow, return, and boiler block and flue gas temperature sensors. The flow temperature is adjustable between 68-194°F [20-90°C].

8.2.6 Low water level protection (flow and content)

The Gas 310/610 ECO is equipped with low water protection based on temperature differences (Δ_T) between flow and return. When the $\Delta_T = 45^\circ\text{F}$ [25°C] (factory setting) the boiler starts modulating down so that it remains operational as long as possible. When the $\Delta_T = 72^\circ\text{F}$ [40°C] the boiler will be at part load.

If the Δ_T continues to rise and reaches 81°F [45°C], the boiler shuts down (note a boiler failure, see section 12.4) and will restart when conditions return to normal. If the boiler is fired dry, it will go to high temperature lock out, failure code **97**.

8.2.7 High limit protection

The high limit temperature protection device switches off and locks out the boiler (showing a flashing fault code, see section 14.4 for details) when the flow temperature exceeds the high limit set point (adjustable parameter, see section 13.2.10). When the fault is corrected, the boiler can be restarted by using the **reset**-key on the control panel.

8.2.8 Air pressure differential sensor (LDS)

At the start of the heat demand, the system checks whether the LDS input is open.

If not, there are (max.) 4 restarts, before the boiler is locked out (**E61**). If the LDS input is open, the fan will speed up and a pressure difference is built up across the boiler. When the LDS control speed is reached the LDS input must close.

If not, there are (max.) 4 restarts before the boiler is locked out (**E08**). Once started the LDS function is switched off for modulation purposes.

8.3 Connections

The terminal strips and boiler connectors can be seen once the control box cover is removed. The left-hand terminal strip (X29) is used for 24-volt connections. The right-hand terminal strip (X27) is used for 120-volt connections. All external connections are made on these terminal strips (see fig. 17). The various connections options are detailed in the following sections.

Fig. 17 Terminal strip

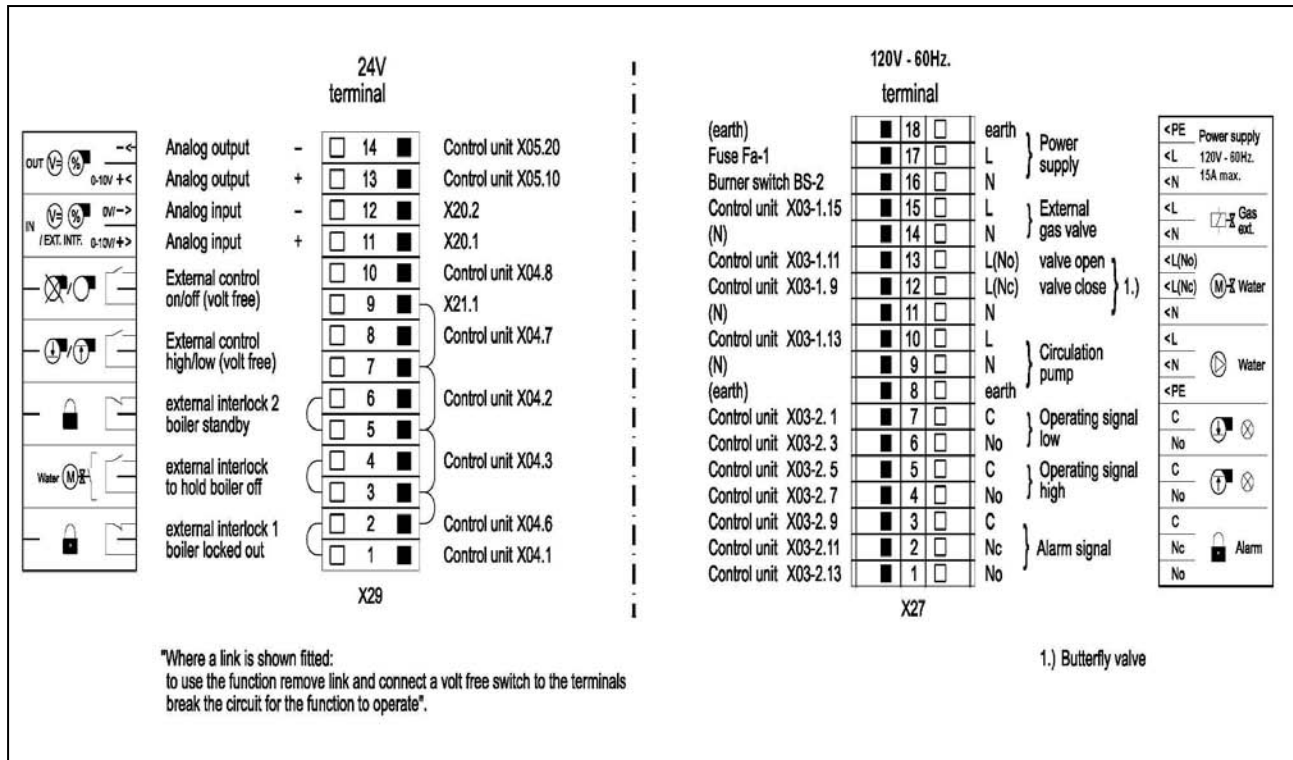

8.4 Wiring Diagram

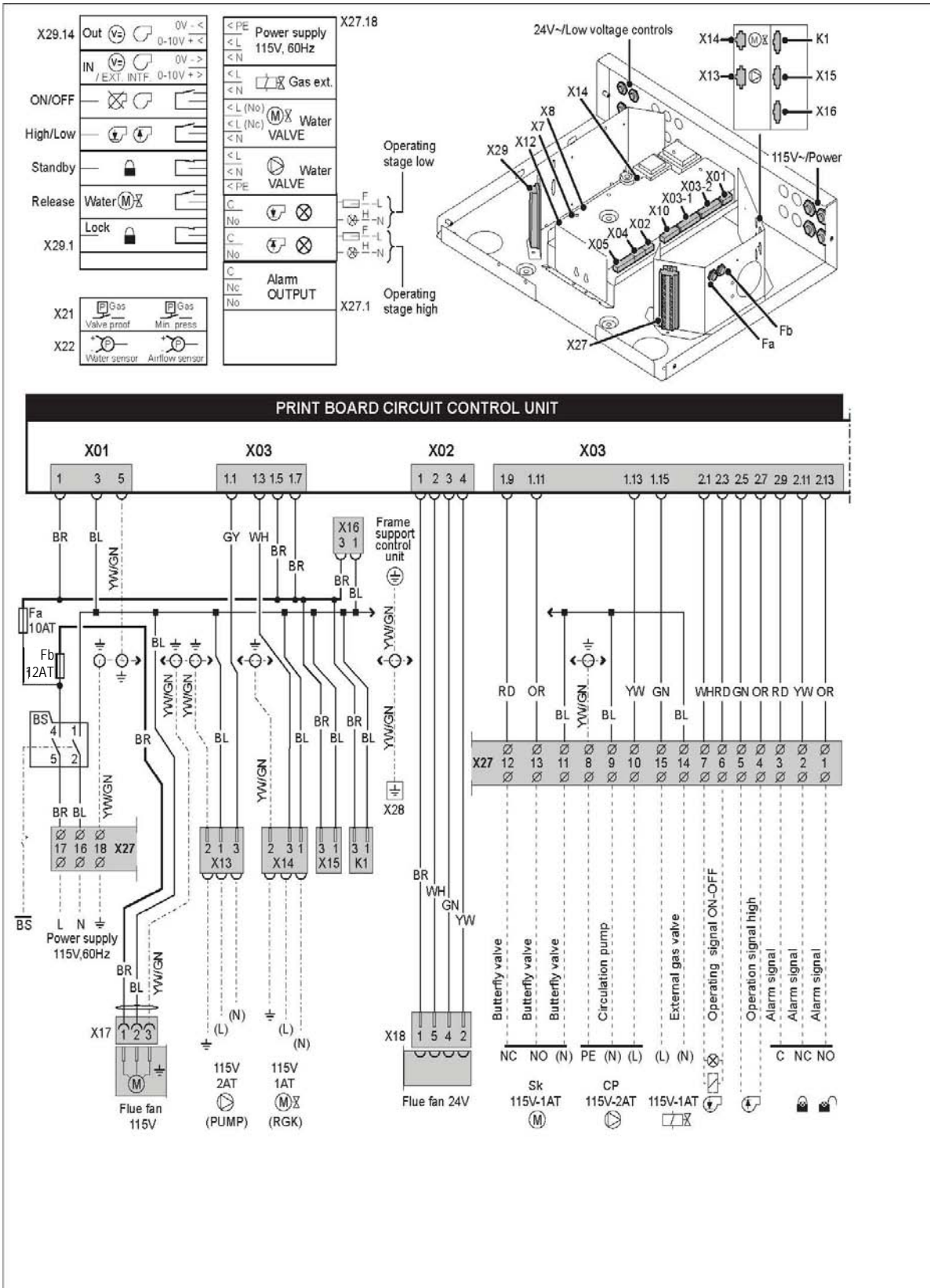
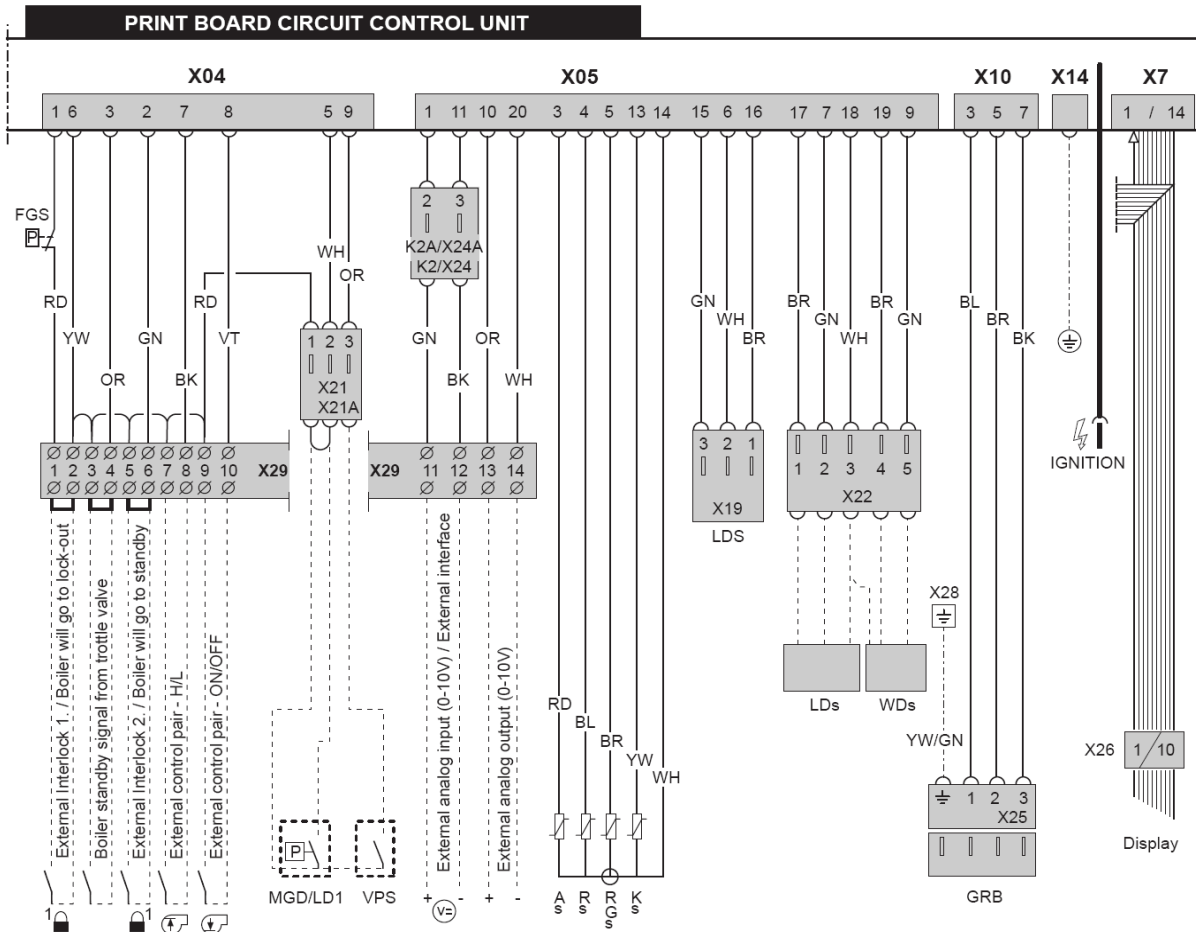

fig. 18 wiring diagram

8.4 Wiring Diagram - Continued

WIRE COLORS		COMPONENTS	CONNECTORS	
BK	BLACK	As	Flow-sensor	
BL	BLUE	BS	Burner switch	
BR	BROWN	CP	Circulation pump	
GN	GREEN	Fa	Fuse control panel	
GY	GRAY	Fb	Fuse fan	
OR	ORANGE	FGS	Flue Gas Switch	
RD	RED	GRB	Safety shut off valve	
VT	VIOLET	Ks	Boiler-sensor	
WH	WHITE	LDS	Air pressure-switch	
YW	YELLOW	LDs	Air pressure sensor	
YW/GN	YELLOW/GREEN	MGD/LD1	Minimum gas pressure switch	
		Rs	Return-sensor	
		RGs	Flue gas-sensor	
		RGK	Flue gas damper	
		Sk	Butterfly valve	
		V	Flue fan	
		VPS	Valve leak proof system	
		WDs	Water pressure-sensor	
			K1	Connector Tem-interface
			X1,X2,X3-1, X3-2,X4,X5, X7,X8,X10,X14	Connector to print board circuit control unit
			X13	Connector circulation pump
			X14	Connector flue gas damper
			X15	Connector external compensator
			X16	Connector external compensator
			X17,X18	Connector flue fan (115V, 24V)
			X19	Connector air pressure switch
			X21	Connector gas pressure-/ gas leak switch
			X22	Connector air pressure-/ water pressure-sensor
			X24	Print board interface RMCI-1400
			X25	Connector safety shut off valve
			X26	Connector display control panel
			X27 ∅	Terminal strip
			X28 ⚡	Terminal strip earth
			X29	Terminal strip 115V, 24V
			-----	Will not be supplied, or wired



Field wiring examples (Additional wiring examples are supplied separately)

Example 1, local modulation

Typical Gas310/610 boiler field wiring

- On/Off control or jumper – modulates according to internal set-point (Connect X29.9 & X29.10)
- LWCO & External Hi-Limit fault attenuation on control, connect devices in series on X29.1 & X29.2 – Generates fault code flashing numbers $\boxed{X} \boxed{1} \boxed{2}$ requires manual reset of safety devices first then reset of the boiler control. \boxed{X} = Code display & $\boxed{1} \boxed{2}$ = U \square display
- Optional flow switch application (Start interlock only)
- Optional LWCO & Safety Hi limit – can be wired on X29.5 & X29.6 if power failures are common, note boiler display will not display fault code, but a shut-off code \boxed{b} , $\boxed{X} \boxed{X}$ (Flashing dots)

LEGEND:	
①	Main fuse disconnect
②	Service switch
③	External Hi Limit
④	External LWCO device
⑤	External Flow Switch (optional not required)
L	Line 120v
E	Earth ground
N	Neutral
L (NO)	Output 120v (normally closed)
L (NO)	Output 120v (normally open)
C	Common dry contact
N_o	Normally open dry contact
N_c	Normally closed dry contact

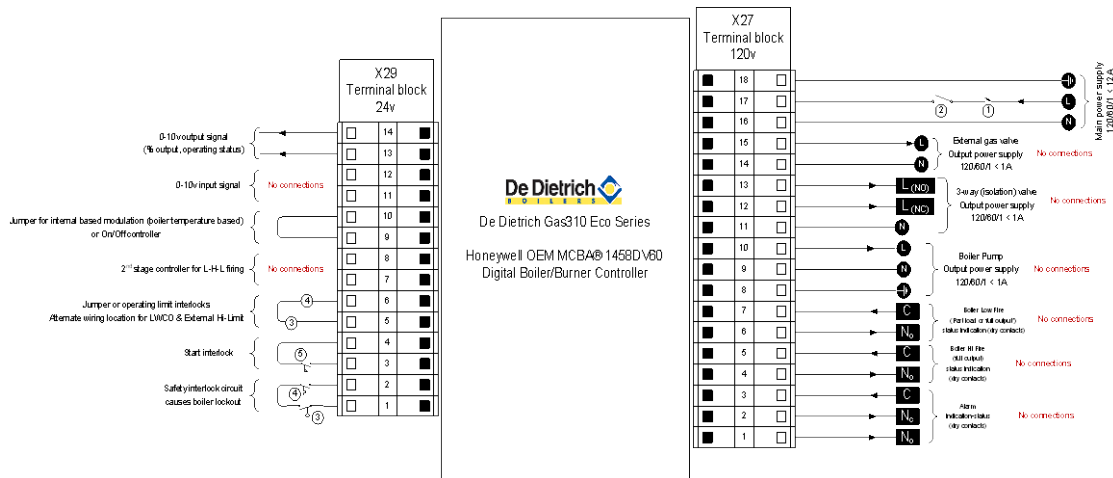

8.5 Switch sequence diagram

8.6 Boiler control

8.6.1 Gas 310 Introduction, Gas 610 each module

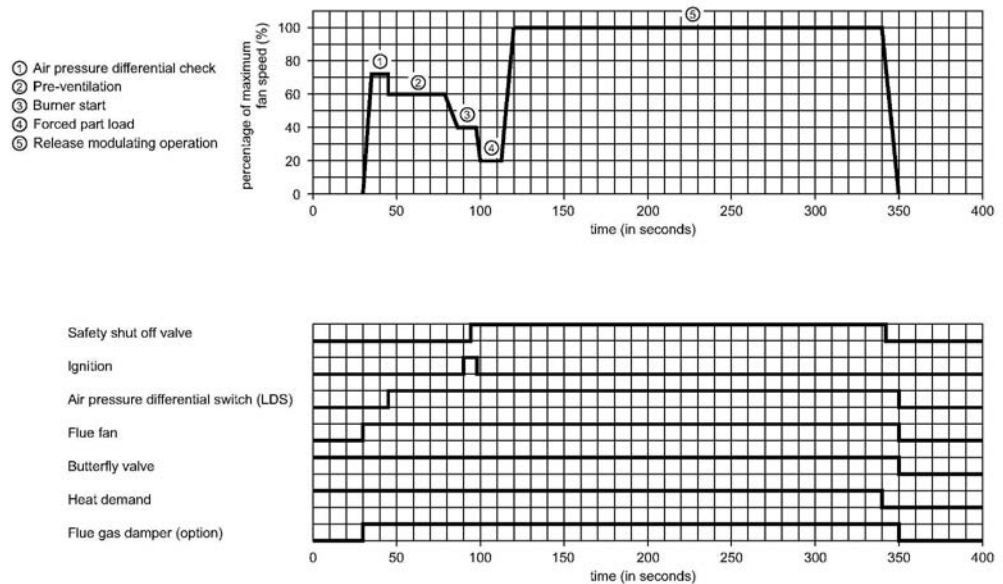

Fig. 19 Switch sequence diagram [04.31H.79.00003]

The De Dietrich Gas 310/610 ECO can be controlled using one of the following methods:

Note: When using on/off control the boiler will also modulate to maintain the flow temp set point (parameter \square)

- Fully modulating, where the output modulates between the minimum and maximum value on the basis of the flow temperature defined by the modulating controller.
- Analog control (0-10 volts), where the heat output or temperature is controlled by a 0-10 volt signal.
- On/off control, (one-volt free relay) where the heat output modulates between the minimum and maximum value on the basis of the flow temperature set in the boiler.

High/low control, (two volt free relays) where the boiler is controlled by means of a 2-stage controller at part load and full load.

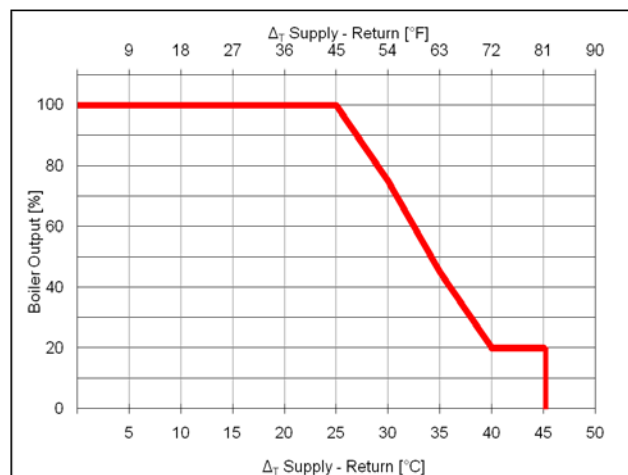

Fig. 20 °output control characteristic

In all cases, modulation is based on the required flow temperature and there is a Δ_T dependent output control with the following characteristic. Up to a Δ_T of 45°F [25°C] (factory setting, parameter \square) the boiler operates at full output. Between Δ_T full load and Δ_T part load the output reduces in linear fashion (see fig. 20).

8.6.2 Gas 310 Modulating controls general (2 wire control)

To make full use of the boiler's modulating feature, a 0-10v [dc] input control will be needed.

Some controls can provide weather compensation to achieve maximum efficiency and minimum boiler cycling whilst maintaining design condition within the building.

A. Modulating boiler control [single boiler]

An optional optimizing weather-compensated boiler control can be used for single boilers. The compensator can regulate the boiler output against outside weather conditions, and provide time and temperature control over the DHW. The compensator is mounted in a reference room (uses an internal sensor to monitor room temperature) and is interfaced to communicate with the boiler's controls via the two wire serial interface. On site connection of the outside and common flow sensors complete the... Set the \boxed{X} value of the boiler control

Operation parameter $\boxed{R_1}$ to $\boxed{I_1}$.

 **Note:** Please refer to the control documentation for installation requirements.

B. Modulating multiple boiler controller

An optimizing, weather-compensated boiler control can be used to control multiple boilers. The compensator can regulate the boiler output against outside weather conditions, and provide time and temperature control over the DHW. The multiple boiler control-compensator is mounted centralized and can be interfaced to communicate with the boiler's control the supplied adapter. On site connection of the outside and common flow sensors complete the installation. Set the \boxed{X} value of the boiler control operation parameter $\boxed{R_1}$ to $\boxed{I_1}$.

Note: Please refer to the control documentation for installation requirements.

8.6.3 BMS Analog control (0-10 Volt DC)

Input resistance $R_{im} = 66 \text{ k}\Omega$.

The heat output modulates between the minimum and the maximum value on the basis of the voltage supplied by an external analog (0-10V) input. To control the boiler with an analog signal, the signal has to be connected on terminals X29-11 (+) and X29-12 (-) of the terminal strip in the instrument panel.

 **Important!!!** When analog control is opted, the on/off –contact and the high/low –contact have higher priority (e.g. frost protection).

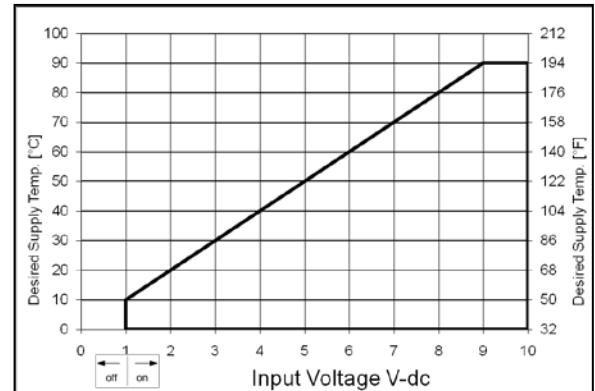

Fig. 21 Temperature control via analog (0-10 Volt) signal

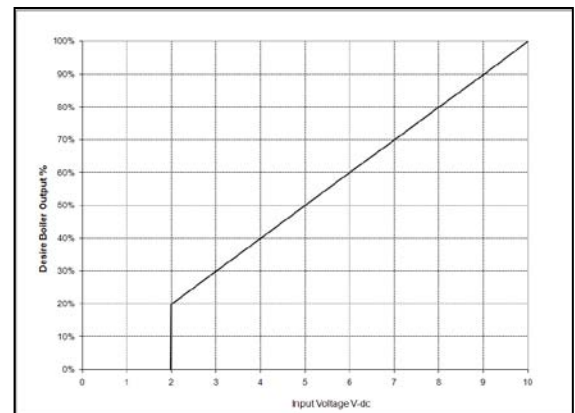
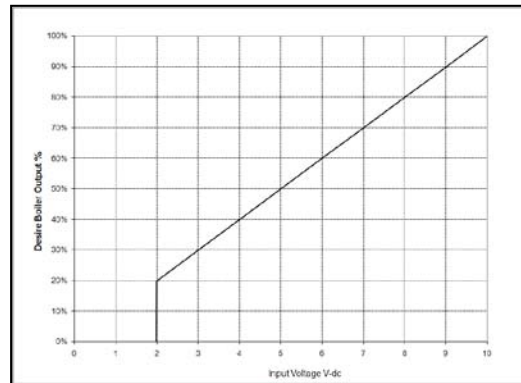

Fig. 22 *output control via analog (0-10 Volt) signal

Gas 310 Temperature based 68 – 194°F [20-90°C]

Set the value of the boiler control operation parameter to . To set the ratio between voltage and the desired flow temperature (see par. 13.2.5 and fig. 21)

0 to 0.9 Volt = boiler off
 1 Volt = Flow temperature set point 50°F [10°C]
 8 Volts = Flow temperature set point 176°F [80°C]

**Output based – fixed parameters (20 to 100%)**

Set the value of the boiler control setting parameter to (see fig. 22)

0 to 1.9 Volt = Boiler off
 2 Volt = Boiler 20% output
 10 Volts = Boiler = 100% output

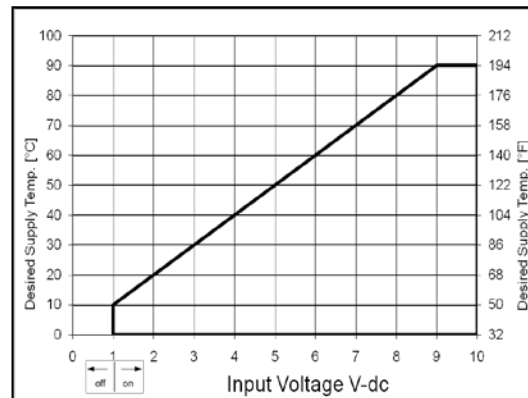
**8.6.4 On/off control (1 X no volt switched pair) internal modulation**

The heat output modulates between the minimum and the maximum value based on the set flow temperature,

terminal connections X29-9 and X29-10. Set the value of the boiler control operation parameter to (on/off).

8.6.5 High/low control 2 stage (2 x no volt switched pairs)

The heat output is controlled between part load (50%, adjustable) and full load by means of a two-stage controller, terminal connection X29-9 and X29-10 low fire; X29-7 and X29-8 high fire.

Set the value of the boiler control operation parameter to . The output percentage on which the boiler runs on low fire can be adjusted with parameter (low fire start point as percentage) in the setting mode. The 'high fire' percentage is dependent of the maximum adjusted output, see setting mode, parameter (maximum output). During this 'high' state modulation on adjusted flow temperature is released.

Gas 610 Temperature based 68 – 194°F [20-90°C] set the value of the boiler control operation

parameter to . To set the ratio between voltage and the desired flow temperature (see par. 13.2.5 and fig. 21)

0 to 0.9 Volt = boiler off

1 Volt = Flow temperature set point 50°F [10°C]

8 Volts = Flow temperature set point 176°F [80°C]

Output based – fixed parameters (20 to 100%), set the value of the boiler control setting parameter to (see fig. 22)

8.6.6 2-Stage control (2 X no volt switched relays)

The heat output on each boiler module stages between the minimum and the maximum value based on the set flow temperature, terminal connections X29-9 and X29-10. Set the value of each boiler control operation parameter to (on/off).

8.6.7 4-Stage High/low control (4 x no volt switched relays)

The heat output is controlled between part load (50%, adjustable) and full load by means of a 4-stage controller, terminal connection X29-9 and X29-10 low fire; X29-7 and X29-8 high fire.

Set the value of each boiler control operation parameter to . The output percentage on which the boiler runs on low fire can be adjusted with parameter (low fire start point as percentage) in the setting mode. The 'high fire' percentage is dependent of the maximum adjusted output, see setting mode, parameter (maximum output). During this 'high' state modulation on adjusted flow temperature is released.

8.7 Other inputs

8.7.1 Shut down input

As standard each boiler module is supplied with a shut down interlock carrying a 24 Volt AC boiler control circuit. This input does not require manual re-set.

Any external devices required to stop the boiler (e.g. limit switches of throttling valves, minimum gas pressure switches) should be wired in series and connected to terminals X29-5 and X29-6, breaking the circuit will activate the safety interlock and put the boiler into a shut-off condition with code . If this input is being used, the wire bridge must first be removed.

8.7.2 Lock-out input

As standard each boiler module is supplied with a lock out interlock carrying a 24 Volt AC boiler control circuit. This input requires manual re-set if activated.

Any external devices required to stop the boiler (e.g. maximum gas pressure switch) must be volt free and should be wired in series and connected to terminals X29-1 and X29-2. Breaking the circuit will activate the safety interlock and put the boiler into a lock out condition, failure code requiring manual intervention to re-set it. If this input is being used, the wire bridge must first be removed.

8.7.3 External interlock

As standard each boiler module is supplied with an external interlock carrying a 24 Volt AC boiler control circuit.

Any external devices required to prevent the boiler from operating (e.g. boiler room ventilation air flow switch, or butterfly valve end switch) must be volt free and should be wired in series and connected to terminals X29-3 and X29-4, breaking the circuit will prevent the boiler from starting. Boiler does not go to lock-out. If this interlock is being used, the wire bridge must first be removed.

8.7.4 Other outputs

8.7.5 Analog output

Depending on the option settings in the service level (see section 13.2.13), the analog output signal is able to transmit the following values: This output relates to terminals X29-13(+) and X29-14(-)

Output Signal [0-10Vdc]	Description
0 Volts	Boiler off - standby
0.5 Volts	Alarm
1.0 Volts	Shut-off
2.0 - 10 Volts	Output between 20 & 100% or Flow temperature between 68 – 212°F [20 - 100°C]

table 06 - Analog °output signal

8.7.6 Operation signal

As standard the boiler is supplied with internal relays to indicate boiler “Low fire” and boiler on “High fire”. The relay contacts are volt free and close to confirm operation.

For the “boiler Low fire” signal connect to terminals X27-6 and X27-7.

For the “boiler High fire” signal connect to terminals X27-4 and X27-5.

For On/Off signal (regardless of firing position): Set parameter \square to 60 in the service level access

Contact load:

- Maximum voltage: 120 V
- Maximum current: 1 A.

8.7.7 Common alarm (Lockout or power ON signal)

Alarm contacts (dry-volt free)

X27.3 (Common) contact

X27.2 (Normally Closed) contact

X27.1 (Normally Open) contact

- For alarm indication status (Boiler Lockout or loss of power), connect remote alarm signal between X27.3 (Common) and X27.2 (Normally Closed)
- For Power “ON” indication status (Normal boiler status), connect remote signal between X27.3 (Common) and X27.1 (Normally Open)

See Section 8.7.6 for operating signal indication (Actual boiler firing signal) connections.

8.7.8 External gas valve control

As standard the boiler is supplied with an internal relay that is energized when there is a heat internal relay that is energized when there is a heat demand, this applies a 120 V supply to terminals X27-15 (live) and X27-14 (neutral). The relay is de-energized when the gas valve multiblock closes at the end of the heat demand. Additional external interlocks (by others) may be required in a multi boiler installation.



Important!!! This supply cannot be used to control an external gas valve if it supplies other appliances.

- External gas valve voltage: 120 Volts
- Maximum current: 1 Amp.

8.8 Optional Inputs

8.8.1 System pressure sensor (optional)

The system pressure sensor shutdown the boiler (with shutoff code **b 6.2**) when the minimum water pressure is reached (adjustable 11-100 psig [0.8 – 6 bar] factory setting = 14.5 psig [bar], see section 12.2.12) the hydraulic pressure sensor must be connected on the 5-pin female plug X22 on the 24-volt terminal strip. Press the **▶▶▶** and **←** simultaneously for 2 seconds to indicate the presence of the pressure sensor in the control.

8.8.2 Gas valve leak proving system VPS (optional)

The gas valve leak proving system checks and operates the safety valves on the gas valve multiblock. The test takes place before the boiler pre-purge mode. In the event of a leak between the 2 valves in the gas valve multiblock, the boiler will lock out and show the failure code **89** or **90** on the display. The gas valve leak proving system must be fitted to the boiler and connected to the 3-pin female plug X21 on the 24-volt terminal strip and the control set to recognize it using the parameter **j** in the setting mode (see section 13.2.13)

8.8.3 Minimum gas pressure switch (suitable for gas pressures up to 14" w.c. [30mbar])

The minimum gas pressure switch (set to 3.5 inches w.c. [8mbar]) shuts down the boiler (shut-off code **b 2.6**) if the inlet gas pressure becomes too low. The minimum gas pressure switch must be connected to the 3-pin female plug X21 on the 24 –volt terminal strip. The connection is automatically detected by the boiler control.

8.8.4 Flue gas damper (Gas 310 – optional, Gas 610 - standard)

In a positive pressure vent application, an optional flue gas damper can be installed to avoid hot flue gases to pass through the boiler during the off periods. A vent damper is required for each Gas 310/610 boiler connected to Cat IV single boiler or Co-vented common venting system.

The flue gas damper [RGK] is wired to the boiler control with a special 4-pin connector marked X14, the damper is an 115v – 60Hz operated damper. See wiring on page 25.

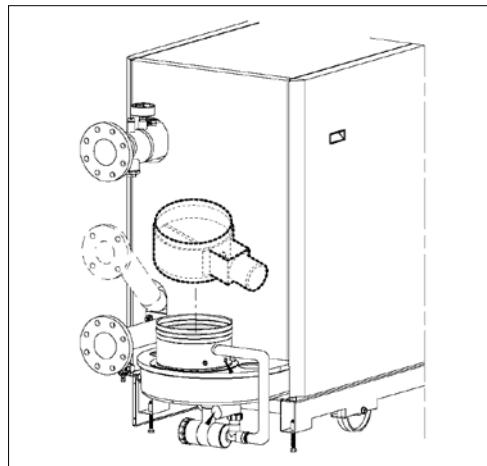

Installation:

1. Install vent damper assembly on to the boiler flue connector observe the flow direction
2. Route vent damper wire harness – supplied in through the boiler casing channels so that it avoid contact with any hot boiler components
3. Remove existing jumper on X14 connector on the boiler control
4. Install the 4-pin from the vent damper

Once the vent damper is installed; the remaining venting can now be completed.

! Confirm the correct operation of the boiler equipped with this vent damper, the damper shall be in its fully open position prior to allowing the boiler to start the pre-purge phase.



This optional device installed or not does not affect the overall efficiency of the boiler.

Please refer to the document supplied with the vent damper for detailed installation information.

8.8.5 Return butterfly valve 3-way valve (supplied by others)

A butterfly valve should be installed in return for each boiler module is hydraulically disconnected from the system. The return butterfly valve is fully open the valve end switch contact is closed, allowing the boiler to run. The return butterfly valve must be connected to terminals X21-11 (neutral), X27-12 (power close) and X27-13 (power open) on the 120-volt terminal strip. The end switch on the return butterfly valve must be connected to the external interlock terminals X29-3 and X29-4 (first remove bridge). After boiler shut-off, the power supply will remain on X27-13 keeping the valve open during the post purge time of the pump (set point code \square), then switch to X27-12 to close the valve (this remains valid even if no pump has been connected to the control box. (also see sections 8.9.1 & 13.1.2



Please refer to the document supplied with the return of 3-way valve for detailed installation information.

8.9 Other connections

8.9.1 Boiler or System pump control

The Gas 310/610 ECO a power supply (120V max 2amps) to run or control an external boiler or system pump. The boiler control will run the pump once every 24hrs when the boiler not enabled to prevent sticking and will also provide a run on period at the end of a heat demand (parameter \square , see section 13.1.2)



Important!! Phase/Neutral sensitive!



Important!! For multiple boiler installations the system pump cannot use this power supply. If the boiler shuts down the system pump will also shutdown.

8.9.2 Frost protection

The boiler must be installed in a frost-free area to prevent freezing of the condensate drain. If the temperature of the heating water drops too low the integrated boiler protection activates under the following conditions.

If the boiler flow temperature:

- Is below 44°F [7°C], the external heating pump connected to the boiler is switched on at minimum capacity;
- Is below 39°F [3°C] the boiler is switched on at minimum capacity;
- Exceeds 50°F [10°C], the boiler and heating pump are switched off again. The pump now has a fixed post-circulation time of 15 minutes.



Important!!

This frost protection only protects the boiler. Other measures must be employed to protect the building and system and will depend which parameters are set or what form of external controls are in use.

9.0 INSTALLATION INSTRUCTIONS FOR GAS INSTALLER

9.1 Gas connection

The Gas 310/610 is suitable for use with natural gas only. The gas connection is at the top of the boiler (see fig. 02). The boiler is fitted with a gas filter as standard to prevent dirt from contaminating the gas valve or burner assembly. An isolating main gas cocks must be installed in the vicinity of the boiler.

- A main gas shutoff valve should be connected to the 2 Inch NPT connection on the boiler, and must be readily accessible and within hand reach.
- Sediment trap must be installed upstream of the main gas cocks shutoff valve.
- The boiler fuel train does not require venting to the atmosphere, other regulators and safety shutoff valves may require venting and relief piping to the atmosphere, consult their documentation.

9.2 Gas pressures

The boiler's main gas valve can accept a maximum inlet pressure up to ½ psi or 14 "w.c. [35 mbar], but MUST be provided with a min. of 3.5 "w.c. [8 mbar] at the gas filter inlet test point when the boiler is operating at max output. Pressures below this level can result in lockouts (for multi gas appliance installations this minimum pressure must be available at each boiler with all gas appliances firing on max output).

Gas system pressure checks:

- The boiler main gas cocks shutoff valve and piping must be isolated from any gas piping pressure testing in excess of ½ psi or 14 "w.c. [35 mbar]
- The boiler main gas cocks shutoff valve and piping must be isolated by closing the main gas cocks shutoff valve during gas piping pressure testing less than ½ psi [3.5 kPa]
- The boiler main gas piping and gas train must be leak tested prior to placing the boiler in operation

9.3 Gas / air ratio control

The boiler has a pressure differential gas/air ratio control. This gas/air ratio control maintains the correct balance of gas and air quantities to the burner at a constant level under variable loads. This ensures clean and reliable combustion and high part load efficiency across the entire load range. Minimum airflow is monitored before a start by an air pressure differential sensor.

10.0 COMMISSIONING

Warning:

If you do not follow the commissioning instructions exactly, a fire or explosion may result causing property damage, personal injury or loss of life.

10.1 Initial lighting

1.  Isolate main power supply
2. Remove the casing on the inspection side.
3. Open the main gas valve.
4. Check the electrical connections including earth.
5. Fill the boiler and the system with water (approximate > 11 psi).
6. Vent all air from the system.
7. Fill the siphon assembly with water.
8. Check the flue gas discharge connection and air inlet duct or air supply connections.
9. Vent the gas pipe, Open the gas cocks to the boiler.
10. Check the inlet gas pressure PI (see fig. 23). Ensure sufficient gas supply pressure > 3.5 "w.c.
11. Check the gas connections for gas leaks.
12. Switch on the main power supply to the boiler.
13. Switch on the boiler operating switch.
14. Switch on the heating pump and check the installation position and direction of rotation.

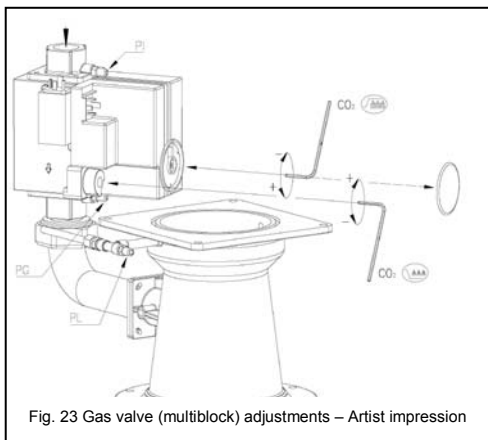





Fig. 23 Gas valve (multiblock) adjustments – Artist impression

15. Adjust the boiler controls to heat demand.
16. The boiler should start with the run sequence indicated in the code-display:

 = Boiler neutral position (No heat demand)

 = Butterfly valve open, if connected; Wait for minimum gas pressure switch to close: Neutral position check of air pressure differential sensor; Vent damper opens (if applicable); The fan runs and the boiler waits until sufficient air transport is established; the air pressure differential sensor must switch to guarantee sufficient airflow.

 = Gas valve leak proving system test (Only if option employed)

 = Pre-purging, drives to high fire position

 = Heating pump starts running; drives to ignition position.

 = Burner is firing a flame is detected

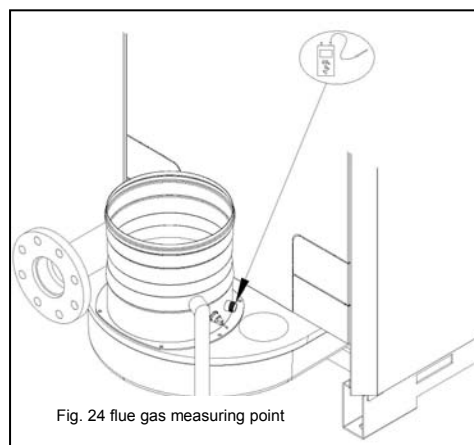







Fig. 24 flue gas measuring point

17 Continued:

a. Check and correct, if necessary, the boiler for correct gas/air ratio set-up. Checking takes place on full and part load, adjustment takes place only on the gas valve multiblock. For checking and adjusting are required: an electronic CO₂-gauge (on the basis of O₂) and a gas pressure gauge. Note that the opening (see fig. 24) around the measuring probe is sealed properly during measurement. Note also that measuring the O₂ levels in the flue gas is necessary, because direct measurement of CO₂ can lead to inaccuracies due to varying CO₂ levels in the natural gas. Connect the gas pressure meter between measuring point PG on the underside of the gas valve multiblock and measuring point PL on the venturi (see fig. 23), ensuring the connections are gas tight.

- a. Run the boiler at full load (forced mode 'high') by pressing the  and [+]-key simultaneously for 2 seconds. The letter  will now appear on the display.
- b. When full load is reached, measure ΔP gas at measuring point P on the underside of the gas valve multiblock and at the measuring point PL on the Venturi and compare to the value in table 7 adjust if necessary using the  adjustment screw on the gas valve multiblock.
- c. Check CO₂- percentage (O₂-percentage) against table 11. If the values exceed the given tolerances, adjust according to fig. 23. Check the flame through the inspection glass, the flame must not blow off.
- d. Run the boiler at part load (forced mode 'low') by pressing the  and [-] keys simultaneously for 2 seconds. The letter  will now appear on the display.
- e. When part load is reached, measure ΔP gas at measuring point P on the underside of the gas valve multiblock and at measuring point PL on the Venturi and compare to the value in table 7 adjust if necessary using the  adjustment screw on the gas valve multiblock.
- f. **Check CO₂-percentage (O₂-percentage) against table 11. If the values exceed the given tolerances, adjust according to fig. 23.**
- g. Remove measuring equipment and seal test points.

Check the flame through the inspection glass, the flame must not blow off. **Repeat the check starting from point 17b until the readings match the values in the tables.** Contact our Service Department if deviations cannot be corrected.

Combustion Readings			
Emission	Unit	Full Load (100%)	Part Load (20%)
CO ₂ Range	%	9.0 ± 0.5	
CO ₂ Set Point	%	9.0 ± 0.15	
O ₂ Range	%	4.8 ± 0.5	
O ₂ Set Point	%	4.8 ± 0.25	
CO Limit	ppm	< 100	

Boiler Models	Gas Pressure Readings*			
	Full Load (100%)		Part Load (20%)	
	Δp [in w.c.]	Δp [mbar]	Δp [in w.c.]	Δp [mbar]
310-5	5.20 ± 0.6	13.0 ± 1.5	0.28 ± 0.08	0.70 ± 0.20
310-6	4 ± 0.6	10 ± 1.5	0.18 ± 0.08	0.45 ± 0.20
310-7	3.80 ± 0.6	9.5 ± 1.5	0.20 ± 0.08	0.50 ± 0.20
310-8	5 ± 0.6	12.5 ± 1.5	0.30 ± 0.08	0.75 ± 0.20
310-9	6.20 ± 0.6	15.5 ± 1.5	0.32 ± 0.08	0.80 ± 0.20

* For reference only. Measured combustion values more important.

 **IMPOTANT SAFETY WARNING:**

The installation of the boiler is not completed until all controls and safety device have been tested and verified for correct function and operation. It is the sole responsibility of the installer to ensure that safety control system and gas ignition system and any there safety control must be tested.

18. Check gas leakage control and minimum gas pressure switch (if installed); Parameter $\square j$ must be set to a value greater than or equal to 8, depending on the connected options (see section 13.2.13). Then set the gas leakage control pressure switch to a switch pressure equal to 50% of the inlet pressure. Check that the measured inlet pressure is not the (higher) closing pressure.
19. Return the boiler to 'user level' by pressing the **reset** key.
20. Heat the system to approximately 176°F [80°C] and switch off the boiler.
21. Bleed the system and check the water pressure.
22. The boiler is now ready for operation.
23. Set the boiler controls to the required values.
24. Check all safety controls and ignition systems for correct operation and safety shutdown function.
25. Send completed commissioning reports to DDR Americas Inc.

**Note:**

The Gas 310/610 ECO is supplied with a number of factory default settings that should be correct for most installations. If there setting values are required: see sections 13.1 and 13.2.

The following operating situations are now possible:

26.
 - a. **Modulating operation:** The output of the boiler modulates on the basis of the flow temperature, asked by the modulating control (see 'Note' in point 25c and section 8.6.2).
 - b. **High/low operation:** The boiler is operating at part load or full load, depending on the heat demand (see section 8.6.5). on the safety boundaries the boiler is going to modulate.
 - c. **On/off operation:** the boiler modulates between minimal and maximum output on the basis of the flow temperature pre-set on the boiler (see section 8.6.4).
 - d. **⚠ Important!!** The boiler will initially operate in forced part load. The factory setting for forced part load time is 30 seconds. This setting is correct if modulating controllers are used (see point 25a). A forced part load time of 3 minutes is recommended for on/off operation (setting mode, parameter $\square g$, see section 13.2.3).
 - e. **0-10 V operation:** Depending on the adjustments, two situations are possible (see section 8.6.3):
 - The given off output varies linear with the sent signal, 2V = 20%, 10V = 100%
 - The given off flow temperature varies linear with the sent signal (depending on parameter $\square a$ and $\square b$); example: 0V – 32°F [0°C], 10V = 212°F [100°C].
 - The boiler modulates on the basis of the set flow temperature (setting range 68-194°F [20-90°C] and a maximum ΔT protection.

Boiler gas ignition control operation and safety shutdown safety check procedure:

1. Shut off electrical power to boiler
2. Shut off main gas supply cocks valve to boiler
3. Restore power to boiler
4. Activate heat demand
5. Observe ignition
6. Observe safety shutdown condition, the boiler shall shutdown then attempt to restart (max 5 automatic restarts, followed by lock-out code = $\square 0 \square 2$ and error on control, confirm shutdown code is correct.
7. Reset the boiler control
8. Open main gas supply cocks valve
9. Observe ignition and note irregular ignition – consult maintenance section of this manual

10.2 Shutdown

1. Switch off the on/off switch of the boiler. With this, a possible boiler control will be without power.
2. Close the main shutoff valve.

 **Important!!** – No frost protection when the boiler power is turned off

11.0 CONTROL AND SAFETY EQUIPMENT

11.1 General

The boiler is supplied with a standard set of defaults pre-programmed for normal operation but can be tailored by the engineer to suit most site conditions. These values are set and read, using the built-in instrument panel or with a laptop/computer or PDA (with optional software and interface).

For tamper proofing and security reasons the control has three levels of access:

1. User level - owner access
2. Service level - access with service code by qualified personnel
3. Factory level - access by PC with factory code

11.1.1 Instrument panel layout

The instrument panel consists of (see fig. 25):

1. Operating switch
2. PC/PDA connection for monitoring
3. Facility for incorporating a weather compensator

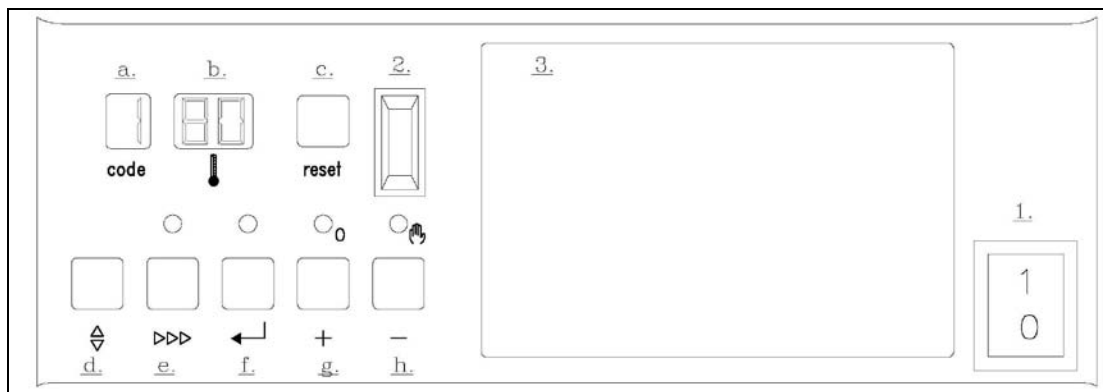



Fig. 25 Instrument panel

The functions of the keys and read-out windows (a-h) are explained below.

 A summary of the key functions can be found in section 16.1 which is helpful when stepping through the modes.



a. Code window:

Display at user level:

- operating mode = only digit or letter
- setting mode = digit or letter with steady dot
- read-out mode = digit or letter with flashing dot
- shut-off mode letter
- forced mode = 'HIGH' letter
- forced mode = 'L°W' letter
- failure mode = flashing digit (current fault)

Display at service level:

- failure mode = flashing digit (failure memory)
- counter mode = alternating + +
- shut-off mode = alternating digit and dot in first section

- b.  window displaying:
 - temperatures
 - settings
 - shut-off or failure codes
- c. **reset** key:
 - reset/unlock key
- d.  key (**mode** key):
 - program function; use this key to select the required mode
- e. **>>>** Key (**step** key):
 - program function; use this key to select a parameter within the mode
- f. **←** key (**stare** key);
 - program function; increase setting
- g. **[+]** key:
 - program function; increase setting
- h. **[-]** key:
 - program function; decrease setting
 - switch function; manual or automatic °operation

11.1.2 LED indicators

The instrument panel has 4 indicating LED's with the following functions:

- The LED above the [-] key (in the  symbol); when illuminated green confirms the boiler is in manual override (see section 11.2)
- The LED above the [←] key indicates that “24 hour pump operation” has activated the heating pump (and the shunt pump if required).
- The LED above the [+] key flashes if the optional hydraulic pressure sensor detects that the water pressure is too low.
- The LED above the [▶▶▶] key flashes if there is no communication with the code key (code key not connected).
- Two LED's flash green when there is no communication anymore between code key and control unit. The boiler will keep on operating. Only after the power supply was switched off and back on, the boiler will refuse to operate.

11.2 Switch function key

Some keys on the instrument panel have dual functions, i.e. a programming and a switch function.

The programming function is described in section 13.

The switch function (on or off) is activated by pressing down the relevant key for 2 seconds. Whether the function is switched on or off is indicated by the indicator for the key, which is either lit or not lit, or by the appearance of a letter in the **code** window.



11.2.1 Manual/automatic operation

If the [-] key is pressed for 2 seconds the boiler will switch on, even if there is no heat demand from an external control. The green LED above the key stays on continuously to indicate a manual heat demand (central heating bridged internally). When the [-] key is pressed for 2 seconds again the boiler will return to automatic central heating operation (green LED off).

 During manual operation the flow temperature cannot exceed its pre-set maximum value. This is to protect the boiler and the system. Parameters can be changed during manual operations.



 **Important!!** If the external heating pump is not connected to the control unit, the pump will not be switched.

11.2.2 Forced mode 'high' ()

By pressing the  and [+] key simultaneously in operating mode during 2 seconds, the boiler will run at maximum power. The letter  will now appear on the display. To protect the boiler and the system, the flow temperature cannot exceed its pre-set maximum value. This is... Parameters can be changed in this mode. By pressing the [+] key and [-] keys simultaneously, the boiler will return to operating mode.

Following a manual override the boiler will return to normal (auto control) if no keys are used within a 15-minute period.

11.2.3 Forced mode 'low' ()

By pressing the  and [-] key simultaneously in operating mode, the boiler will run at minimum power. The letter  will now appear on the display. To protect the boiler and the system, the flow temperature cannot exceed its pre-set maximum value. This is... Parameters can be changed in this mode.

By pressing the [+] key and [-] key simultaneously, the boiler will return to operating mode.

Following a manual override the boiler will return to normal (auto control) if no keys are used within a 15 minute period.

11.3 Display of value

The display has only two digits available therefore values over this are displayed as followed:

- Values from 00 to 99 will be indicated without any decimals points.
- Values from 100 to 199 will be indicated by a dot between both digits e.g. $\boxed{0}\boxed{0}$ =100, $\boxed{1}\boxed{0}$ =110, $\boxed{9}\boxed{9}$ =199
- Values from 200 to 299 will be indicated by a dot behind every digit e.g. $\boxed{0}\boxed{0}$ = for 200, $\boxed{1}\boxed{0}$ =210, $\boxed{9}\boxed{9}$ =299
- Value over 300 will be indicated by showing the thousands, hundreds, tens and units in separate alternating pairs. (see section 12.2 and 12.5)
- Negative values (for instance when using an external sensor or when sensors are not connected) will be indicated by a dot behind the last digit, e.g. $\boxed{1}\boxed{0}$ indicates -10.

12.0 OPERATING MODE

12.1 Operating mode (X □□)

During normal operation the **code**-display show the status (position in cycle) of the boiler, with the Ⓢ -display indicating the actual flow temperature.

The digits or letters in the code-display have the following meaning:

Code	Description
$\boxed{0}$	Standby, there is no heat demand
$\boxed{1}$	Pre-ventilation (pre-purge time 30 seconds, post purge time 3 seconds)
$\boxed{2}$	Trial for ignition
$\boxed{3}$	Burner firing and flame detected
$\boxed{4}$	N/a
$\boxed{5}$	Waiting mode, startup check, air sensor LDs sufficient pressure
$\boxed{6}$	Control stop (burner off + post purge)
	a) Flow temperature T1 > set point 9°F [+5°C]
	b) Flow temperature T1 > desired set point modulating control 9°F [+5°C]
	c) flow temperature T1 > parameter $\boxed{1}$
	d) Difference flow T1 and return T2 > 10°C (factory setting) Starting condition is ≤ 10°C
$\boxed{7}$	End of heating demand, pump post purge. During cycling prevention delay-time the boiler will remain in state $\boxed{7}$ and will not react to heat demand.
$\boxed{8}$	N/a
\boxed{b}	Shut-off mode (see section 12.4)
\boxed{H}	Forced full load (HIGH)
\boxed{L}	Forced part load (LOW)
\boxed{E}	Gas leakage control
$\boxed{C}\boxed{0}\boxed{L}$	Burner cooling

Table 08

12.2 Read-out mode (X □□)

Read-out mode is used to display various values. Press the \diamond key until \square appears in the **code** window (dot flashes). Select the required code using the $\triangleright\triangleright\triangleright$ key.

Code	Description	Read-out range/comments	Read-out (e.g.)
\square	Flow temperature °F [°C]	Actual value	$\square\square$
\square	Return temperature °F [°C]	Actual value	$\square\square$
\square	Flue gas temperature °F [°C]	Actual value	$\square\square$
\square	Heat exchanger temperature °F [°C]	Actual value	$\square\square$
\square	Flow temperature set point °F [°C]	Calculated value	$\square\square$
\square	Heat demand status (1 st digit)	$\square X$ = on/off contact open	$\square\square$
		$X\square$ = on/off contact closed	
	Air pressure diff. sensor (LDs, 2 nd digit)	$X\square$ = air pressure diff. sensor °pen	
		$X\square$ = air pressure diff. sensor closed	
\square	Switch-on temperature for central heating operation °F [°C]	Demanded value	$\square\square$
\square	Requested (permitted by boiler control) output % is displayed, irrespective of boiler control setting	$\square\square$ - $\square\square$ = 100% demanded value	$\square\square$
\square	Calculated output %	$\square\square$ - $\square\square$ = 100% actual value	$\square\square$
\square	Analog input voltage - volts	$\square\square$ - $\square\square$ = 100% actual value	$\square\square$
\square	Control strategy (see section 12.3)	$\square\square$ - $\square\square$	$\square\square$
\square	Current water pressure	$\square\square$ - $\square\square$ ÷ 10 bar units, then x 14.5 for psi units. with pressure sensor (optionally), no pressure sensor $\square\square$	$\square\square$
\square	N/a		
\square	Fan speed	$\square\square$ - $\square\square$	$\square\square$ then $\square\square$ = 4000*
\square	Ionization level (flame signal)	$\square\square$ - $\square\square$ = x 0.1µA	$\square\square$
\square	Unique boiler code	$\square\square$ - $\square\square$	$\square\square$
\square	Pressure difference over air pressure differential sensor	$\square\square$ - $\square\square$ = x 0.1 mbar, then x 0.4 for inches w.c. units	$\square\square$









Table 09 Read-out mode user level

*The displayed value has 4 digits. The display alternately flashes from $\square.\square\square\square$ to $\square\square\square\square$ with code indicating the value being read. In this example: fan speed 4000 i.e.

12.3 Control strategy



During normal operation, the boiler control can operate according to a specific strategy. Most control strategies are meant to keep the boiler burning for as long as possible, regardless of changes in flow and flow problems, etc.

The control strategies can be viewed in read-out mode with the code .

-  = modulate up (control below ionization limit)
-  = modulate down (maximum temperature difference between flow and return)
-  = minimum output (return temperature higher than flow temperature)
-  = modulate down (flue gas temperature too high)
-  = pump/boiler on (frost protection)
-  = zero-flow protection 2 (minimum output)
-  = zero-flow protection 1 (modulate down)
-  = boiler block temperature too high (control stop)

12.4 Shut-off (

12.4.1 Shut-off

During shut-off, the **code** window displays  and the  window indicates the shut-off code.





 **Important!!** Shut-off is, a normal boiler operating function and does not represent a boiler failure. However, this may indicate a system problem or an incorrect parameter setting.

12.4.2 Shut-off mode

In shut-off mode last shut-off and corresponding operating codes can be reviewed. With PC (version Recom PC and higher) or PDA the last six shut-off's can be reviewed.

During this particular mode both dots in the  window flash.

The last shut-off and corresponding operating codes and applicable temperatures are stored in the micro-processor memory and can be read out in shut-off mode as follows:

- Enter the service code    (see section 13.2).
- Press the  key until  appears in the code window (flashing digit with flashing dot).

Select the required step with the    key.











































Code		Description
	 	Shut-off code (see table 23)
	 	operating code, at shut-off intervention (section 12.1)
	 	Flow temperature, at shut-off intervention
	 	Return temperature, at shut-off intervention
	 	Flue gas temperature, at shut-off intervention
	 	Boiler block temperature, at shut-off intervention
 	 	Time from shut-off intervention (PC software °only)
	 	Ionization level (analog), at shut-off intervention
	 	operating hours (hundred thousand, and ten thousand)
	 	operating hours (thousand and hundreds)
	 	operating hours (tens and units)
	 	Fan speed at shut-off intervention (thousands and hundreds)
	 	Fan speed at shut-off intervention (tens and units)

Table 10 Shut-off in service level

The letters and numbers in the **code** window and the  window are explained in *appendix 16.2*.

12.5 Counter mode (1, 2 and 3) (service level)

12.5.1 General

The boiler control records various data on the combustion trend of the boiler. This data can be read out in counter mode. The following data can be read out:

- Hours run
- Total number of start attempts
- Number of shunt pump operating hours
- Number of shunt pump starts
- Number of internal resets (control unit)
- Number of hours energized (control unit)

12.5.2 Reading out counter mode

First enter the service code 1 2 (see section 13.2).

Press the \diamond key until the required code (see table 15) appears in the **code** window.

1	Hours run
2	Number of successful ignitions attempts
3	Total number of start attempts
4	Number of shunt pump operating hours
5	Number of shunt pump starts
6	Number of internal reset (control unit)
7	Number of hours energized (control unit)

Table 15 Counter mode codes

The counter has 6 digits. The **code** window displays the following (in sequence):

Code figure, 1st 1, 2nd 2, 3rd 3 with a value in the \downarrow window.

Code figure	Meaning of readout in \downarrow window
1	Total number or total number of hours in the hundred thousand and ten thousands
2	Total number or total number of hours in thousands and hundreds
3	Total number or total number of hours in tens and units

Table 16 Counter mode readout

Example:

Code window	\downarrow window	value
1	2 1	210000
2	5 7	5700
3	5 3	53

This means 215753 Hours run

13.0 SETTING MODE

13.1 User level setting mode (X □□)

Setting mode is used to change various settings to suit individual requirements. The required code is selected by pressing the \diamond key until \square appears in the **code** window. Select the required code with the \ggg key. Now press the $+$ key to increase a setting or the $-$ key to decrease a setting.

Press the \leftarrow key to store the new setting. The new value will flash twice in the \square window to confirm the setting.

Cede	Description	Setting range and explanation if necessary	Factory setting
\square	Flow temperature set point (see section 13.1.1)	$\square\square - \square\square = 68 - 194^{\circ}\text{F}$ or $\square\square - \square\square [20-90^{\circ}\text{C}]$ Boiler operating limit set point, also maximum setting if external control is used.	$\square\square = 176^{\circ}\text{F}$ $\square\square = 80^{\circ}\text{C}$
\square	Pump post purge setting (see section 13.1.2)	$\square\square =$ Pump post purge = 10 seconds $\square\square - \square\square =$ pump run on in minutes $\square\square =$ Pump operates continuously	$\square\square$
\square	Boiler control setting (see section 13.1.3)	Control mode (modulating, on/off, etc.)	$\square\square$

Table 17 Settings mode user level

! **Important!!** Changing \square and \square should only be on design engineer's advice.

13.1.1 Flow temperature (\square)

The required flow temperature is adjustable from 68-194°F [20-90°C].

The following diagram shows a typical example of this procedure:

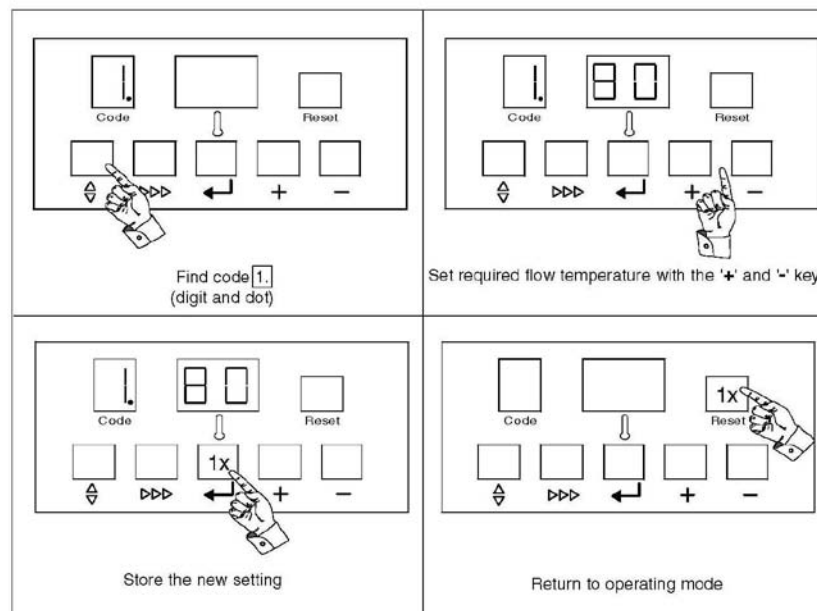

Fig. 26 Setting flow temperature

13.1.2 Pump run on time (P)

Pump run on time can be adjusted (Please refer to installation contractor)

-Press the \diamond -key until the digit P (with dot) appears in the **code**-display.

-Press the $\triangleright\triangleright\triangleright$ -key until the digit 2 (with dot) appears in the **code**-display.

-Set the required value, using the [+] and [-]-keys.

- Press the \leftarrow -key to store the new value (value will flash twice).
- Press the **reset**-key to return to operating mode.

Code	Ⓢ	Description
P.2	00	Pump post purge = 10 seconds
P.2	XX	Pump purge time for 1 to 15 minutes (XX = 01 to 15)
P.2	99	Continuous pump operation

Table 18 Adjustments pump run on time

13.1.3 Boiler control (R)

Setting mode, parameter R, can be set to different values (see table 19).

Proceed as follows to change the boiler control:

- Press the \diamond key until the number R (with dot) appears in the **code** window.
- Press the $\triangleright\triangleright\triangleright$ key until the letter R (with dot) appears in the **code** window.
- Use the [+] and/or [-] keys to specify the required setting.
- Press the \leftarrow key to store the new setting (flashes twice to confirm).
- Press the **reset** key once to return to operating mode.

Code	Ⓢ	Description
R	X0	heat demand off
	X1	Heat demand on
	2Y	on/off and High/Low
	3Y	on/off and modulated on flow temperature
	4Y	External 0-10v analog signal on temperature
	5Y	External 0-10v analog signal on output %

Table 19 Boiler control settings.

Example: boiler control 4Y indicates that the boiler is controlled by means of a 0-10 volt signal modulated on the basis of flow temperature (X= 4). Heat demand is on (Y = 1).

13.2 Setting mode service level (only for the qualified service engineer) (X □□)

To prevent accidental, unauthorized access by non-qualified persons the control system requires an input code to gain access to the second level of boiler control.

-Press the \diamond and $\triangleright\triangleright\triangleright$ keys simultaneously and hold. The **code**-display now shows a letter X with a random number in the Ⓢ-display.

-While holding both keys pressed, set the Ⓢ-display to X12, using the [+] or [-] keys and press the \leftarrow key.

-The display will flash twice, confirming acceptance of the access code.

-Release the keys and X12 will disappear from the display.

⚠ Important!! Changing the pre-set values without reference to the tables contained in this manual may result in incorrect boiler operation.

- The service settings can now be reached by pressing the \diamond -key until the digit P (with dot) appears in the **code**-display. Set the required value, using the $\triangleright\triangleright\triangleright$ key.
- To delete the service code, press the **reset**-key once.
- If no keys are pressed over a 15 minute period, the service code will delete automatically.

Code	Description	Setting Range	Factory setting
4	Minimum fan speed (hundreds) see section 13.2.1	06 - 60 x 100 rpm	310/610-5 = 15 = 1500 rpm
			310/610-6 = 16 = 1600 rpm
			310/610-7 = 11 = 1100 rpm
			310/610-8 = 11 = 1100 rpm
			310/610-9 = 12 = 1200 rpm
5	Minimum fan speed (units) see section 13.2.1	00 - 99 x 1 rpm	
6	Maximum fan speed (hundreds) see section 13.2.2	10 - 60 x 100 rpm	310/610-5 = 5500 rpm
			310/610-6 = 5600 rpm
			310/610-7 = 3650 rpm
			310/610-8 = 4200 rpm
			310/610-9 = 4500 rpm
7	Maximum fan speed (units) see section 13.2.2	00 - 99 x 1 rpm	
8	Forced part load running time, see section 13.2.3	01 - 30 x 10 sec.	03
9	Cycling prevention delay-time, see section 13.2.4	01 - 30 x 10 sec.	02 = 20 seconds
a	Required flow temperature at 0 volts (analog signal), see section 13.2.5	58 - 22 = -58 to 122°F or 50 - 50 = -50°C to 50°C	00
b	Required flow temperature at 10 volts (analog signal), see section 13.2.6	22 - 00, 04, 08, 00 = 122 to 480°F or 50 - 49 = 50°C to 249°C	12 = 212°F or 00 = 100°C
c	Switch point High/Low operation signal, see section 13.2.6 a) Signal "Low fire" if value less than b) Signal "High fire" if value is greater than	06 - 60 x 100 rpm	310/610-5 = 3500 rpm
			310/610-6 = 3900 rpm
			310/610-7 = 2500 rpm
			310/610-8 = 2700 rpm
			310/610-9 = 3500 rpm
d	Shunt pump post purge time, see section 13.2.7	00 = 1 seconds 01 t° 15 = minutes. 99 = continuous	00
e	ΔT from control stop point start point, see section 13.2.10	9 - 54 = 9 - 54°F - 30 = 5 - 30°C	05 50 = 50 of or 10 = 10°C
f	Maximum flue gas temperature, see section 13.2.9	76 - 48 = 176 to 248°F or 80 - 20 = 80 to 120°C	48 = 248 of or 20 = 120°C
g	High limit temperature set point, see section 13.2.10	94 - 12 = 194 to 212°F or 90 - 00 = 90 to 100°C	12 = 212 of or 00 = 100°C
h	Modulation start point ΔT, see section 13.2.11	5 - 54 = 9 to 54°F or 05 - 30 = 5 to 30°C	77 = 45 of or 25 = 25°C
i	Minimum water pressure, see section 13.2.12	00 - 60 = x 0.1 bar units or x 14.5 psi units	08 = 0.8 bar or 11.6 psi
j	Adjustments options/accessories, see section 13.2.13	00 - 15	00
l	"Low" fan speed with H/L control parameter R = 21, see section 13.2.14	06 - 60 = x 100	310/610-5 = 1500 rpm
			310/610-6 = 1600 rpm
			310/610-7 = 1100 rpm
			310/610-8 = 1100 rpm
			310/610-9 = 1200 rpm
p	Boiler type; Appears only after replacing the control unit	50 - 98	depends on output variant

Table 16 Service level setting mod

13.2.1 Minimum fan speed (4 and 5)

Parameter 4, adjustable between 06 and 60 (x100 rpm) parameter 5, adjustable between 0 and 100 (x 1 rpm).

This setting is only active if setting 21 has been selected in the boiler control: high/low control (see section 13.1.3). The value relates to the percentage output when the boiler is running at 'low'. The percentage 'high' position depends on the set maximum central heating speed.

13.2.2 Maximum fan speed (6 and 7)

Parameter 6 adjustable between 10 and 60 (x100 rpm) and parameter 7 adjustable between 0 and 100 (x 1 rpm). The maximum speed can be limited at a lower value in the software by changing parameters 6 and 7.

! Important!! Do not modify these settings, factory settings.

! Important!! Only make changes after consulting DDR Americas Inc. support department.

13.2.3 Forced part load time (8)

Parameter adjustable between 0 and 300 seconds. The boiler always starts with a specified output for a certain time. The boiler can then be sent to the minimum position (20% of output) for a specific period, independent of the heat demand.

13.2.4 Cycling prevention delay time (9)

Parameter (9) adjustable between 0 and 300 seconds. These values set a minimum off time following a control stop / end of a heat demand to prevent cycling taking place. When, after this delay time flow temperature lies less than 9°F [5°C] above return temperature (check °n water flow), the boiler will restart.

13.2.5 Required flow temperature at 0 – 10 volts (a and b)

Start point (0 volts): parameter a, adjustable between -58 and 122°F [-50°C and +50°C]

This value sets the required flow temperature at 0-volt

signal input. End point (10 volts): parameter b, adjustable between 124 and 480°F [+51°C and +249°C] this value sets the required flow temperature at 10-volt signal input (restricted by the maximum flow temperature set-point and the maximum output).

These settings only apply if boiler control 41 has been selected: 'external analog input 0-10V on the basis of flow temperature'.

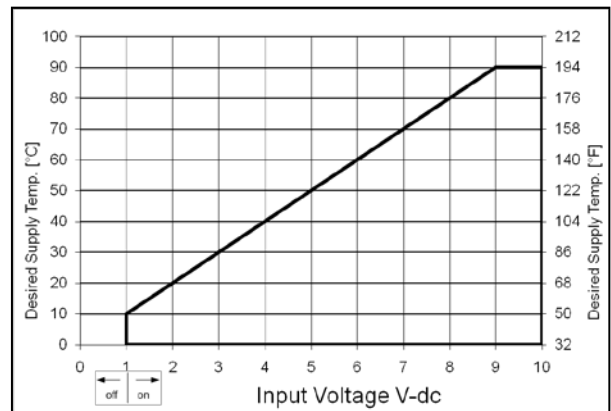

13.2.6 Switch point high/low operation signal (L)

Parameter L, adjustable between 0 and 60 (x100) rpm. This parameter enables setting the switch point between "low fire" and "high fire." A fan speed below the set value will cause a "low fire" signal. A fan speed above the set value will cause a "high fire" signal. An "ON/OFF"

signal can be obtained by setting parameter L to 60 = 6000 rpm

13.2.7 Shunt pump post-circulation time (d)

Parameter d, setting 00 = 10 sec; 99 = continuous and adjustable between 01 and 15 = number of minutes.

Continuous water circulation is advisable if there is a danger of the heating system freezing up.

13.2.8 Δ_T from control stops point to start point

Parameter \boxed{E} , adjustable from 9 to 36°F [5 to 20°C]

This value sets the flow temperature at which the boiler will cut back in after a control stop.

The boiler will always goes to a control stop when the flow temperature equals the flow set-point temperature >

+9°F [> +5°C] The ΔT defines when the burner is switched on again. A value of 18°F [10°C] indicates the temperature has to drop 9°F [5°C] below the calculated flow temperature set point before the boiler starts to run again, cut back in temperature = flow set-point (80) + 5 – parameter \boxed{E} (10), i.e. 176 + 9 – 18 = 167°F [80 + 5 – 10 = 75°C]

13.2.9 Maximum flue gas temperature (\boxed{F})

Parameter \boxed{F} , adjustable between 176 and 248°F [80 and 120°C] This value sets the maximum operating flue gas temperature – non metallic vent flue systems.

13.2.10 High limit temperature setting (\boxed{G})

Parameter \boxed{G} , adjustable between 194 - 230°F [90 - 110°C] This value sets the high limit temperature at which the boiler will shutdown in a lockout condition requiring manual intervention.

 **Important!!** If the factory setting is reduced, a corresponding reduction in flow set-point will be required otherwise the min. flow rate may be affected.

13.2.11 Modulation start point at ΔT (\boxed{H})

Parameter \boxed{H} , adjustable between 18 and 54°F [10 and 30°C] this value sets the flow/return Δ_T point at which the control modulation begins. The boiler starts to modulate at the set-point and will be at minimum output if the Δ_T continues to rise to 72°F [40°C]. At 81°F [45°C] Δ_T the boiler will shut-off (shut-off code \boxed{b} $\boxed{3.0}$). For installations with low flow rates the starting point modulation can be brought forward (i.e. 27°F [15°C]), closer matching boiler output to system demand. In systems with small volume flows the modulation start point can be brought forward. The boiler is better equipped to anticipate low heat demand. The factory set-point should be correct for most installations. The setting start point should only be changed if absolutely necessary.

13.2.12 Minimum water pressure (\boxed{I})

Parameter \boxed{I} , adjustable between 0 – 58 psi [0 – 4 bar]. This setting only applies if an optional hydraulic pressure sensor has been connected. This value sets the point at which the boiler will shut-down if the system pressure falls below it. The boiler will resume normal operation when pressure is restored.

13.2.13 Adjustments options/accessories/units (\boxed{J})

Parameter \boxed{J} is adjustable between 0 and 31. This setting is only applicable if options from table 17 are connected to the boiler. The control unit detects which options have been connected by means of the value of this parameter and adjusts the boiler control on this basis.

The required feedback message (as output in % or as temperature is °F or °C) can also be selected here if the (standard) analog output is used. A list of values that have been assigned to specific options can be found in

Adding together the values of the options used gives the parameter \boxed{J} setting

Example (Factory setting is always = 0)

- Water pressure sensor on = 1
- Analog output % = 0
- Gas leakage control VPS on = 8
- Imperial units of / PSI = 16

Options	Value	Sum
Boiler water pressure sensor off	0	
Boiler water pressure sensor on	1	
Analog output Heat output %	0	
Analog output Temperature of [°C]	4	
Gas leakage control VPS off	0	
Gas leakage control VPS on	8	
Metric units °C & bar	0	
Imperial units °F & psi	16	
Parameter \boxed{L} :		...

The sum of these settings provided parameter setting \boxed{L}

$$(1) + (0) + (8) + (16) = \boxed{25}$$

Table 17 adjustment options/accessories

13.2.14 “low” speed with H/L control (\boxed{L})

Parameter \boxed{L} , adjustable between 10 and 60 (x100) rpm. This setting only applies if the boiler is in High/Low control mode (parameter \boxed{R} = 21).

13.2.15 Boiler type (\boxed{P})

This code appears only when replacing the control unit. After placing the new control unit, code $\boxed{P05}$ appears automatically in the display. The value $\boxed{05}$ must be changed in to the correct value for your boiler type (see mounting-instructions of the service unit)

14 FAULT-FINDING































Code		Description
		Failure code (see table 19)
		operating code, with failure intervention (section 12.1)
		Flow temperature, with failure intervention
		Return temperature, with failure intervention
		Flue gas temperature, with failure intervention
		Boiler block temperature
		Time from failure (with PC software only)
		ionization level (analog)
		operating hours (hundred thousand and ten thousand)
		operating hours (thousands and hundreds)
		operating hours (tens and units)
		fan speed at failure (thousands and hundreds)
		Fan speed at failure (tens and units)

Table 22 Service level failure mode



14.1 General

- If the boiler does not start up, check the following:
- Is a 120 V supply present?
- Is there a heat demand?
- Has the boiler control (parameter ) been set correctly ?(see section 13.1.3)

If the above items have been verified and the boiler does not start, this indicates a failure. In the case of a failure signal, both the **code** window and the  window will flash. Except for failure  (does not flash).





 **Important!!**

Keep a record of the failure codes before resetting (numbers, including flashing digits and dots) and quote them when asking for technical support or consult the failure code tables in this manual. The failure code is needed to find the cause of the fault quickly and correctly. For further details on the various failure codes and possible causes refer to table 23.



 Apart from failure codes (lock-out), the system also knows shut-off codes (see section 12.4). In the latter case only the two dots in the  window will flash and the **code** window will display . A shut-off code may refer to a system problem or incorrect setting.

14.2 Failure mode ( ) (service level)

The latest failure and corresponding operating codes and applicable temperatures are stored in the micro-processor memory and can be read out in failure mode as follows:



- Enter the service code   (see section 13.2).
- Press the  key until  appears in the code window (digit flashes).
- Select the required step with the  key.



In the above example:



The return temperature sensor is defective (=failure code ) , during burning (= operating code ) with a flow temperature of 127°F [53°C], return temperature of 104°F [40°C] and a flue gas temperature of 136°F [58°C]. The boiler block temperature was 145°F [63°C], the ionization level was 1.8 µA, and the boiler had 118026 operating hours and a speed of 2667 rpm. The time elapsed after the failure can only be read on a PC or laptop.

14.3 Cooling mode

This mode enables maintenance on the burner and/or the heat exchanger to be carried out more efficiently. In this mode, the fan runs at maximum speed for two° minutes, which cools down the boiler rapidly. When this mode is active, the system does not respond to heat demands.

 **Important!!** This mode can only be activated if there is no heat demand on the boiler. The code  indicates that the mode is active ( for cooling).

The mode is activated by pressing the  and  keys simultaneously (during normal °operating status with n° heat demand).

The mode can be terminated prematurely by pressing the  and  keys simultaneously.

14.4 Failure (lock-out) codes (requires user intervention, manual reset of control)

When a failure code is displayed, both the **code** window and the  window will flash alternately. Except for failure **F03** (does not flash).

Failure	Description	Cause/check points
00	Flame simulation, (flame detected in the off position)	- Burner glows as a result of high CO ₂ percentage (> 10% CO ₂) - Check ignition/ionization electrode gap 1/8" or [3-4mm] Gas valve is leaking or is stuck open, check and replace
01	Short Circuit in 24v circuit	Check; - Wiring to sensors - Wiring to gas valve
02	No flame or ionization signal after 5 attempts	a) N° ignition spark, Check; - Connection of ignition cable and spark plug cover - Ignition cable and electrode for breakdown - For 'flash over' between spark plug cover and earth - Electrode distance, should be 1/8" or 3.5mm - Condition of burner set (burner set / electrode seal) earth b) Ignition spark is present, but no flame. Check; - The gas main cock valve is open - There is sufficient inlet gas pressure > 3,5 "w.c. [8.7 mbar] - The gas pipe has been purge of air - The gas valve multiblock is energized, during ignition - The electrode is clean and fitted correctly - The gas pip is not blocked or fitting correctly - The air supply or flue gas discharge is not blocked/fitted incorrectly - The gas/air mixture is set correctly c) There is flame, but there is insufficient ionization < 2µA, Check; - The condition of the electrode and earth - The temperature sensors for leakage current
03	Gas valve multiblock defective	Control unit does not recognize gas valve multiblock, check; - The wiring on the gas valve has been disconnected or not fitted - The gas valve is not defective (burned °out or short-circuit)
F03	Fuse 3 blown	Replace fuse 3
04	Permanently locked out	Mains voltage has been disconnected during lock out, solution; reset (original lock-out usually return automatically)
05	No processor handshake (or external influences)	Fault in control unit or fault due to EMC influences, Reset first if fault persists, replace control unit. If fault still persists, locate and remove possible external EMC sources
06	Input failure; sensors are short circuiting	Check the wiring of the temperature sensors. If fault persists, replace control unit. If fault still persists, locate and remove possible EMC sources.
07	Gas valve multiblock relay fault	Gas valve multiblock defective or not connected.
08	Air pressure differential sensor does not maintain check level	Check;
08	Air pressure differential sensor does not maintain check level	- The air supply or flue gas discharge for blockages/ installation faults. - The air pressure differential switch and connections
11	Fault on internal communication bus (I ² C-bus) when reading EPROM	Check - The multiple wire cable in the instrument panel for short circuit - Moisture on the display - Find and remove and EMC sources
12	Locked input open (external safety controls) LWCO & Hi Limit	- Maximum thermostat (=external protection), connected to terminals X29.1 & 29.2 on the terminal strip, has tripped or jumper has been removed. - Fuse F3 on automatic burner unit is defective
17	Gas multiblock protection	Gas valve multiblock defective or not connected.
18	Flow temperature too high	Check; - Flow - System as has proper air elimination - Temperature sensors for deviations - Water pressure in the system
20	Excessive fan speed	Check; - Fan setting parameters - Fan cable is defective or poor connection, if failure persist fan or control unit may be defective.

28	Fan not operating	- Fan defective - Fan cable is corroded, resulting in absence of voltage or control signal.
29	Fan operates continuously or signal incorrect	- Check the fan cable connectors on both the fan and the automatic burner unit side. - Fan electronics defective - Excessive negative chimney pressure
30	Max ΔT exceeded	Check; - Flow - System as has proper air elimination - Water pressure in the system
31	Temperature sensor fault	Short circuit of flow temperature sensor
32	Temperature sensor fault	Short circuit of return temperature sensor
35	Temperature sensor fault	Short circuit of flue gas temperature sensor
36	Temperature sensor fault	Flow temperature sensor not connected or defective
37	Temperature sensor fault	Return temperature sensor not connected or defective
38	Air pressure differential sensor short circuited	- Check the connecting cable of the air pressure differential sensor - Air pressure differential sensor is defective or not connected
39	Air pressure differential sensor open	- Check the air pressure differential sensor connecting cable for short circuiting, etc. - Air pressure differential sensor is defective
40	Temperature sensor fault	Flue gas temperature sensor not connected or defective
43	one or more parameters are out of limits	The input of the parameter(s) are incorrect
45	Hydraulic pressure sensor short circuited	- Check the hydraulic pressure sensor connecting cable for short circuit, etc... - Hydraulic pressure sensor is defective
46	Hydraulic pressure sensor open	- Check connecting cable of the hydraulic pressure sensor for short circuit, etc... - The hydraulic pressure sensor is defective or not connected
52	Maximum flue gas temperature exceeded	Check the heat exchanger for fouling on the flue gas side
61	Air pressure differential sensor not opening	Check; - Is the air pressure differential sensor defective - Has the wiring been short circuited - Excessive positive chimney pressure
77	Weak flame ionization signal during operation (after 4 restarts during 1 heat demand)	- Flue gas recirculation, check venting & heat exchanger for leaks - Insufficient air flow due to blockage - Check the boiler settings
83	Boiler block temperature too high	Check; The heating pump is operating - There is sufficient water flow through the boiler - The water pressure is > 11 psi or 0.8 bar
89	Gas leak VA1 (optional)	The VPS gas leakage control has detected a leak, Check for external leaks, otherwise replace gas valve multiblock
90	Gas leak VA2 (optional)	The VPS gas leakage control has detected a leak, Check for external leaks, otherwise replace gas valve multiblock
91	Air pressure differential sensor fault	Air pressure differential sensor fault during pre-purge (after 4 restarts) Check; Is the air pressure differential sensor defective - Has the wiring short circuited - Excessive high positive chimney pressure
94	Boiler block temperature > flow temperature + hysteresis	Check; - The heating pump is operating - There is sufficient water flow through the boiler - The water pressure is < 11 psi or 0.8 bar
95	Temperature sensor fault	Short circuit of boiler block sensor
96	Temperature sensor fault	Boiler shut-off sensor is not connected or defective
97	Boiler block temperature too high	Check; - The heating pump is operating - There is sufficient water flow through the boiler - The water pressure is < 11 psi or 0.8 bar
other codes	Control unit has internal fault	Proceed as follows with all non-listed codes - Press the reset button once - Check that the wiring is not short circuited - If the fault persists, contact our service department

Table 23 Failure codes



WARNING!! Do not reset the boiler control until you can identify and have resolved the problem. Unresolved problems could cause personal injury or damage to the boiler and controls.

15 INSPECTION AND MAINTENANCE INSTRUCTIONS

15.1 General

The De Dietrich Gas 310/610 ECO has been designed to need minimum maintenance, but to ensure optimum efficiency, we advise that once a year the boiler should be checked and if necessary cleaned and reset. All service and maintenance must be carried out by a qualified heating contractor with the relevant training and certifications.

15.2 Cooling mode

This mode enables maintenance on the burner and/or the heat exchanger to be carried out more efficiently. In this mode, the fan runs at maximum speed for two minutes, which cools down the boiler rapidly. When this mode is active, the system does not respond to heat demands.

⚠ Important!! This mode can only be activated if there is no heat demand on the boiler. The code $\square \square \square \square$ indicates that the mode is active ($\square \square \square \square$ for cooling).

The mode is activated by pressing the $\triangleright \triangleright \triangleright$ and $[+]$ keys simultaneously (during normal operating status with no heat demand). The mode can be terminated prematurely by pressing the $[+]$ and $[-]$ keys simultaneously.

15.3 Annual Inspection

The annual inspection of the De Dietrich Gas 310/610 as follows:

- Check combustion characteristics, full and part load (see section 10.1)
- **Note:** When checking combustion the CO₂ levels should be in accordance with the values in table 11 with a tolerance of +/- 0.5%. If the levels are outside these tolerances, adjustment to the levels must be made in accordance with a tolerance of +/- 0.15%.
- Check flue gas temperature. If flue gas temperature is more than 86°F [30°C] above the boiler return water temperature the heat exchanger must be cleaned (see section 15.4.5).
- Check/clean the condensate siphon (refill with clean water).
- Check for leaks (waterside, flue gas side and gas soundness).
- Check flue and air inlet system is clear and gas/water tight.
- Check system pressure.
- Check control settings.
- Check ionization level, minimum 3 μA dc (see 12.2, parameter $\square \square$).

If ionization level < 3 μA dc or is not present, check:

- Is flame shape stable and color as described in commissioning instructions?
- Check ignition probe earth.
- Check condition of ignition/ionization probe replace if necessary.
- Replace electrode at least every 2 years.
- Clean any oxides/deposits with sandpaper or fine emery cloth.
- Check shape of probe and ignition gap, i.e. 3 to 4 mm (see fig. 36).
- Check temperature sensors for resistance values against fig. 28 (temp vs. resistance on sensors).
- Check and clean if necessary the gas filter (see section 15.4.10).
- Check air box and dirt trap (see section 15.4.1).

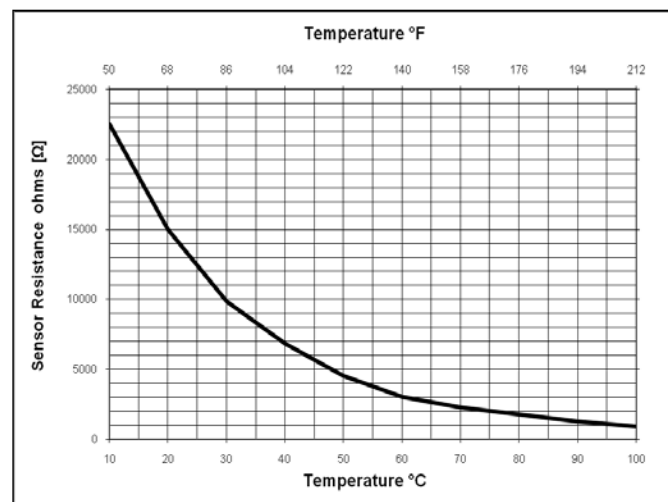

Fig. 28 Sensor resistance graph

15.4 Maintenance

If during the annual inspection combustion results indicate that the boiler is no longer operating at the optimum level additional maintenance should be carried out as follows:

i The Gas310/610 ECO boiler or any of its components does not contain any crystalline silica.



Warning – Electrical Shock Hazard:

Please label all wires prior to disconnecting when servicing this boiler. Wiring errors can cause improper operation and dangerous operation. Verify boiler operation after service!!

Note:

Please ensure that the gas supply and main power supply is isolated before any maintenance work is carried out on the boiler. Care should be taken when stripping the boiler for maintenance making sure that all parts, nuts, washers and gaskets, etc. are kept safe, clean and dry for re-assembly. Following maintenance/cleaning, the boiler should be re-assembled in the reverse order re-placing gaskets and joints where found necessary.

All general cleaning should be carried out with compressed air, a soft brush or damp cloth to avoid damaging components. (Solvents must not be used).

Remove front and end casing panels – lift casing panel slightly upwards and tilt toward you lift again clear of the bottom rail.

15.4.1 Inspection of air box and dirt trap

The air box has a dirt trap on the inlet side. Check this for dirt, leaves, etc. If the boiler is closed, the clamping strip under the casing must be removed first, check using a mirror if necessary.

Check the air box for dirt using a lamp. If the air box is dirty, it must be dismantled and blown clean. If the air box is dirty, the following components must also be dismantled and blown clean:

- non return valve
- venturi
- fan



Important!! Ensure the balancing clips in the impeller stay in place!



Important!! The sealing between the burner and the mixing blend may be sticky. Prevent the sealing from tearing. Damaged or hardened sealing must always be replaced.

15.4.2 Cleaning the non return valve

Use compressed air or a synthetic brush to clean the non return valve.



Fig. 29 non return valve being cleaned with soft brush

15.4.3 Cleaning the Venturi

Use compressed air or a synthetic brush to clean Venturi. Make sure that the hose between gas valve and Venturi is clear and in good condition.



Fig. 30 Venturi being cleaned with compressed air

15.4.4 Cleaning the fan

Use compressed air or a synthetic brush to clean the fan, be careful not to disturb the balance clips on the vanes.

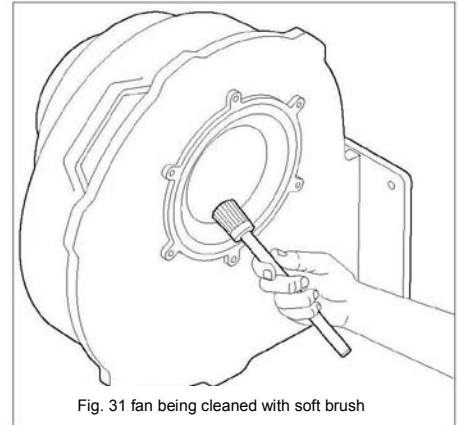

Fig. 31 fan being cleaned with soft brush

15.4.5 Cleaning the heat exchanger

Release the retaining nuts from heat exchanger cover plate, remove plate, being careful not to damage the gasket, store safely. Heat exchanger can be washed with clean water, if badly contaminated, clean with a small stiff bristle "bottle type" brush or use the special cleaning tool (supplied optional). Care should be taken when using water in the confined space of the boiler casing to avoid contaminating the electrical controls. Compressed air can also be used but care should be taken to ensure disturbed dust, etc, does not contaminate the rest of the boiler and controls. Replace the heat exchange plate after cleaning and retighten the retaining nuts.

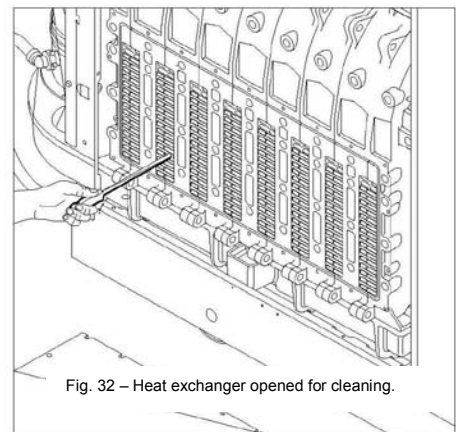

Fig. 32 - Heat exchanger opened for cleaning.

15.4.6 Cleaning the burner assembly

Clean the burner assembly by using compressed air only – between 30 – 70 psi [2-5 bar] with the nozzle positioned a min of 3/8" [10mm] away and towards the face of the burner. Check the retaining bolts are tight. If the burner is removed from the front plate ensure burner-retaining screws are tight on re-assembly

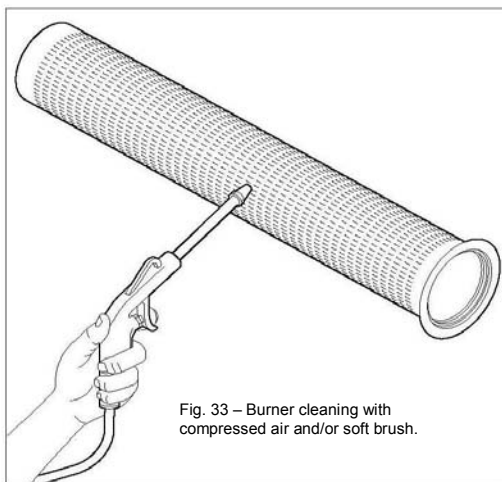
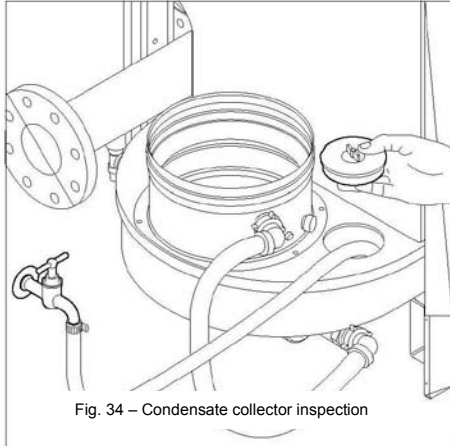

Fig. 33 - Burner cleaning with compressed air and/or soft brush.

15.4.7 Cleaning the condensate collector

Clean the condensate collector by removing the inspection cover (next to the flue gas discharge) and then rinsing the collector with water



15.4.8 Cleaning the siphon

Remove the complete siphon (located underneath condensate collector beneath the flue connection). Remove siphon, clean and refill with clean water and re-fit.

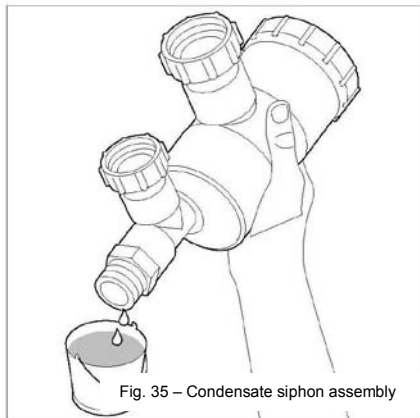

15.4.9 Cleaning/Replacing the Ignition/Ionization electrode

Remove safety bracket from the heat exchanger then remove the two retaining screws on the electrode assembly, remove assembly and examine for wear and dirt, clean and re-gap electrode 1/8" [3mm] re-fit if in good condition (replace gasket if necessary).

Replace electrode assembly if necessary – then discard screws and gasket and fit replacement assembly c/w new gasket and screws making sure that the earth connection is in good condition and in contact with the base plate and re-fit safety bracket.

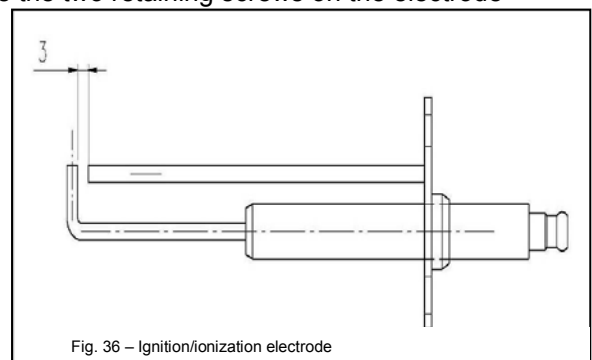

15.4.10 Gas filter check

Measure the pressure differential Δ_P at measuring points, P_i and P_u (see fig. 37) on the gas filter.

- If the Δ_P value is above 4.0" w.c. [10 mbar]: gas filter must be replaced.
- If the Δ_P value is between 2.4 - 4.0" w.c. [6-10 mbar]: measure outgoing pressure on P_u . If this value is below 7" w.c. [18 mbar]: gas filter must be replaced.
- If the Δ_P value is below 2.4" w.c. [6 mbar]

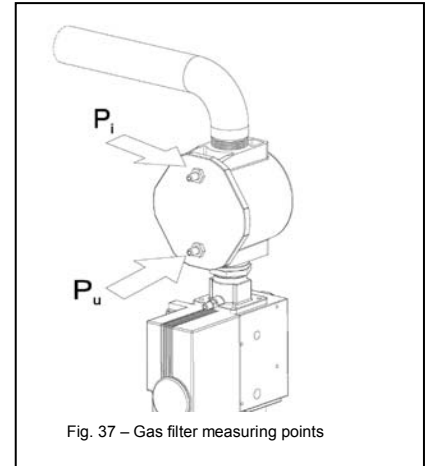

Fig. 37 – Gas filter measuring points

15.4.11 Inspection glass cleaning

Remove the two retaining screws on the inspection glass holder, clean and replace.

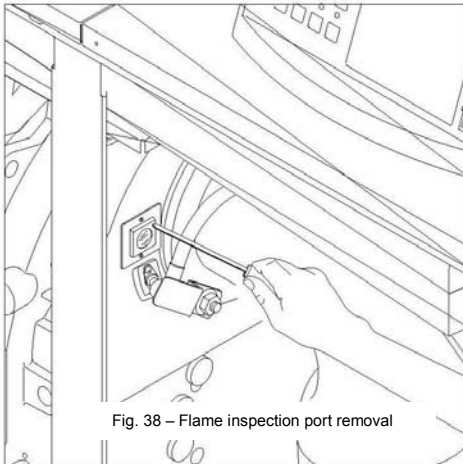

Fig. 38 – Flame inspection port removal

Re-assemble boiler in reverse order, check front plate gasket and insulation piece, replace if required. Also check the gasket on fan and on gas valve, replace if necessary. Ensure that all cables are routed correctly using existing clips and ties were possible to ensure that they do not touch any hot parts of the boiler.

⚠ Important!! Ensure that wires do not come into contact with hot boiler parts

Commission boiler in accordance with section 10.1; complete site report and/or boiler log book if present

Other items requiring periodic checks:

At least once a year the must be checked, cleaned or replaced as required:

- Venting system leaks or poor connections
- Venting system sagging or damaged vent components
- Debris in vent terminal screens [exhaust and air inlet]
- Boiler room kept clear of flammable liquids, combustibile materials,
- The combustion air supply source(s) clear without any obstructions
- Combustion air filter if fitted, replace as necessary
- Inspection of combustion air supply venting

Additional boiler check list or routine boiler maintenance checklist has been provided on page 66

15.5 Exploded view and spare parts list (right hand version shown)

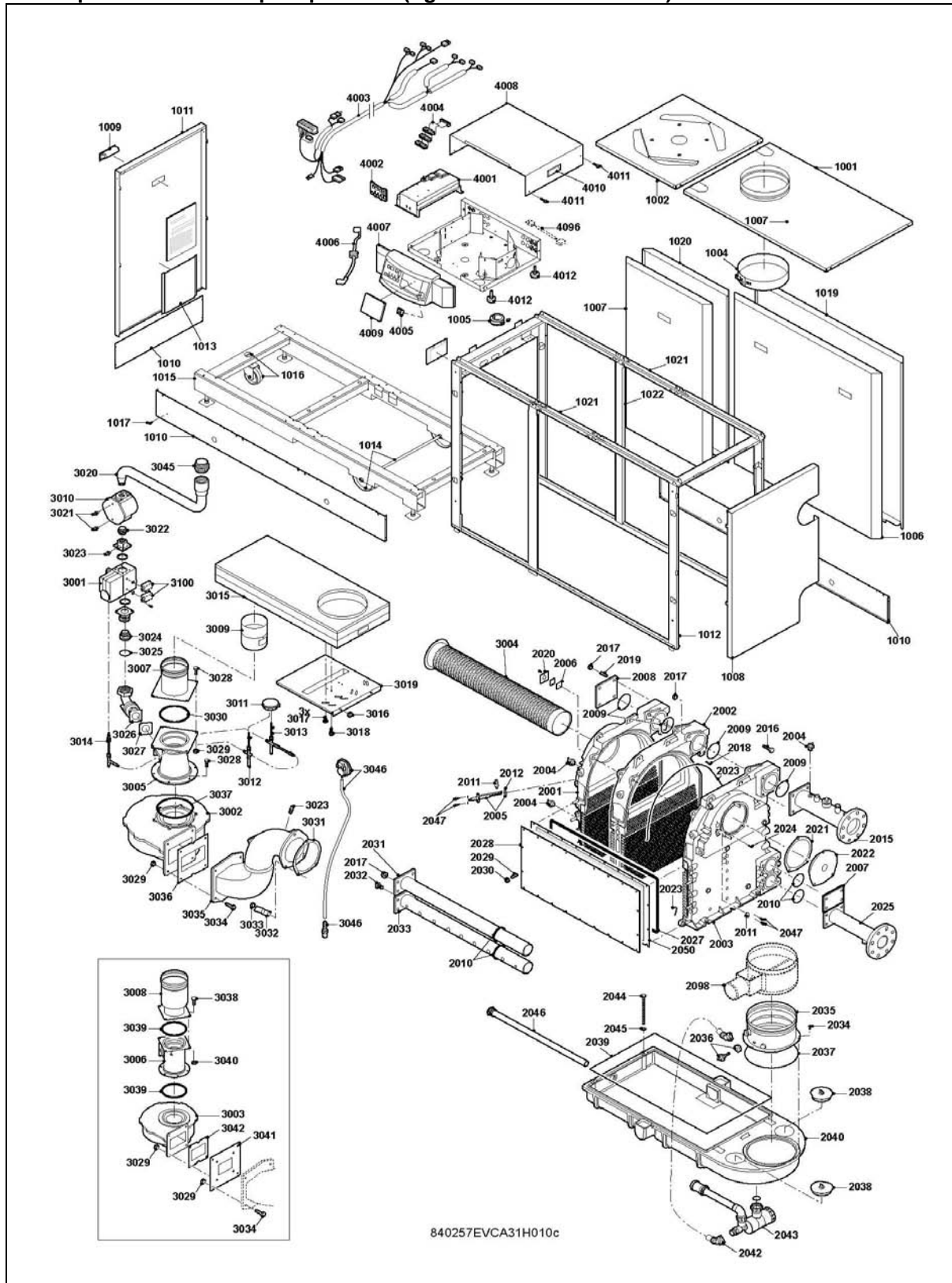

Fig. 39 Exploded view

Part #	Description	Item #
boiler casing/frame		
S100410	Casing top panel 5 sections	1001
S100410	Casing top panel 6 sections	1001
S100411	Casing top panel 7 sections	1001
S100412	Casing top panel 8 sections	1001
S100413	Casing top panel 9 sections	1001
S100414	Casing top switch instrument end	1002
58816	Clamp band 260mmØ	1004
58042	Bracket 2"	1005
S100415	Front and rear casing panel 5 or 6 sections	1006
S100416	Front and rear casing panel 7,8 and 9 sections	1006
S100417	Front and rear casing panel (grey)	1007
S100418	End casing panel right hand connections	1008
S100419	Casing panel handle	1009
S100420	Set casing plinths 5 and 6 sections	1010
S100421	Set casing plinths 7,8 and 9 sections	1010
S100422	End casing panel	1011
S100423	Set casing corner posts (set of 4)	1012
49427	Documentation holder A4	1013
57800	Main wheels with axle	1014
54565	Base frame 5 and 6 sections	1015
54568	Base Frame 7,8 and 9 sections	1015
58606	Caster wheel (steering)	1016
S14254	Sheet -metal screw 4 , 2x9,5 (20 pc's.)	1017
S100424	Front and rear casing panel 5 and 6 secs.	1019
S100425	Front & rear casing panel 7,8 & 9 sections (red)	1019
S100426	Front and rear casing panel	1020
S100427	Casing support 5 & 6 sec.	1021
S100428	Casing support 7,8, 9 sec.	1021
S100429	Casing support central	1022
Boiler heat exchanger		
S5 4500	Section right hand end	2001
S57699	Section intermediate	2002
S5 4501	Section left hand end	2003
S44698	Temp. sensor; return, block & flow NTC 12K/007	2004
S5 4583	Electrode ignition/ionization	2005
S45004	Glass inspection c/w gasket & 2 screws	2006
S100430	Flange blank return	2007
S100431	Flange blank flow	2008
54525	O-ring Ø 107 x 5mm	2009
54526	O- ring 81,92 x 5,33	2010
54584	Cover plate	2011
54563	Gasket for electrode ignition/ionization	2012
S100433	Supply pipe	2015
183	Bolt M12X40mm	2016
42859	Nut angle M12	2017
62346	Dowel Ø12 x 20	2018
54527	Stud M12	2019
S54822	Mounting frame (for inspection glass)	2020
54528	Gasket for cover plate/burner	2021
S5 4585	Cover plate for burner hole	2022
25696	Silicone sealant rtv 106	2023
58462	Dowel burner	2024
S100434	Return pipe	2025
30629	Sealing silicone red 7 mm (per meter)	2027

Part #	Description	Item #
Premix burner		
S100441	Valve gas multi block 5 sections	3001
S100442	Valve gas multi block 6 sections	3001
S100443	Valve gas multi block 7-8-9 sections	3001
S100444	Fan 5 -6 sections	3002
S100445	Fan 7 -8-9 sections	3003
S100348	Burner for 6 sections	3004
S100347	Burner 5 sections	3004
S100331	Burner 9 sections	3004
S100329	Burner 7 sections	3004
S100330	Burner 8 sections	3004
S5 4593	Venturi assembly 7 -8-9 sections	3005
S5 4591	Venturi assembly 5 sections	3006
S5 4592	Venturi assembly 6 sections	3006
S5 4512	Venturi connecting piece Ø 130 mm	3007
S5 4513	Venturi connecting piece Ø 100 mm	3008
S5 4517	Air intake damper Ø100 mm with o-rings	3009
S100487	Gas filter Dungs 1½"	3010
S100460	Air differential pressure switch - Vent safety	3046
S59202	Tube gas test point	3012
S59203	Tube air pressure test point	3013
S59204	Tube pressure compensation test point	3014
S59738	Air box 7,8 and 9 sections	3015
S44483	Nut M8 (10 pc's.)	3016
S14254	Sheet -metal screw 4 , 2x9,5 (20 pc's.)	3017
22222	Bolt M6x16	3018
S100446	Air box	3019
S100447	Pipe gas supply 5 sections	3020
S100448	Pipe gas supply 6 sections	3020
S100449	Pipe gas supply 7 sections	3020
S100450	Pipe gas supply 8 sections	3020
S100451	Pipe gas supply 9 sections	3020
19609	Pressure test nipple ¼"	3021
40139	Adapter 1.½"x1.¼"	3022
1035	Pressure test nipple 1/8"	3023
54549	Adapter 1.¼"	3024
51163	Gasket Ø 56x42x2	3025
S100452	Gas supply pipe 1.¼" w/ Test ring valve	3026
58603	Gasket for venturi	3027
S155 24	Bolt M8 x 16 (10 pc's.)	3028
S59818	Nut M8 (20 pc's.)	3029
54595	O-ring Ø 142 x 3,5mm	3030
54528	Gasket for cover plate/burner	3031
58622	Bracket plug cap guard	3032
42859	Nut angle M12	3033
141	Bolt M8 x 30mm	3034
S100453	Mixing chamber/pipe	3035
S59651	Gasket fan 7,8 and 9 sections	3036
59652	O-ring Ø 180 x 3,5mm	3037
59638	Bolt angle M5 X 20	3038
58609	O-ring Ø 111 x 4mm	3039
S46687	Nut angle M5 (10 pc's.)	3040
54580	Fan adapter plate 5 -6 sections	3041
S59650	Gasket fan	3042

S54520	Access plate heat exchanger 5 sections	2028
S54521	Access plate heat exchanger 6 sections	2028
S54522	Access plate heat exchanger 7 sections	2028
S54523	Access plate heat exchanger 8 sections	2028
S54524	Access plate heat exchanger 9 sections	2028
53544	Stud M8x20mm	2029
55558	Nut M 8	2030
S54538	2nd return water pipe blind 5 sections	2031
S54539	2nd return water pipe blind 6 sections	2031
S54540	2nd return water pipe blind 7 sections	2031
S54541	2nd return water pipe blind 8 sections	2031
S54542	2nd return water pipe blind 9 sections	2031
593	Plug no. 290 3/8"	2032
S54533	Return water distribution pipe 5 sections	2033
S54534	Return water distribution pipe 6 sections	2033
S54535	Return water distribution pipe 7 sections	2033
S54536	Return water distribution pipe 8 sections	2033
S54537	Return water distribution pipe 9 sections	2033
22222	Bolt M6x16	2034
S54548	Flue gas connection Ø 250mm	2035
S49297	Sensor flue gas temperature NTC 12kohm 3%	2036
54598	Sealant silicone red 7 mm L=790mm	2037
S54529	Inspection cover (condensate collector)	2038
54562	Sealant silicone red 10 mm per meter	2039
S100435	Condensate collector 5 sections	2040
S100436	Condensate collector 6 sections	2040
S100437	Condensate collector 7 sections	2040
S100438	Condensate collector 8 sections	2040
S100439	Condensate collector 9 sections	2040
S58818	Hose PVC 27/19	2042
S58611	Siphon assembly complete	2043
54587	Bolt M12 X 180mm	2044
S100114	Washer Ø 13mm (20 pc's.)	2045
S100440	Pipe 5 sections	2046
S48950	Screw M4 x 10 (50 pc's.)	2047
113324	Insulation front plate heat exchanger 6 sec.	2050
113323	Insulation front plate heat exchanger 5 sec.	2050
113325	Insulation front plate heat exchanger 7 sec.	2050
113327	Insulation front plate heat exchanger 9 sec.	2050
113326	Insulation front plate heat exchanger 8 sec.	2050
S59727	Flue gas damper MUK Ø 250mm.	2098
S58823	Cleaning device L = 560 mm.	

S100488	Adapter 2" NPT (Gas inlet pipe)	3045
S58602	Air-pressure sensor Huba 4030	3011
S58604	Gas leakage control or gas pressure control	310/6100
Control		
S100454	Control board MCBA	4001
S43563	Fuse glass 2 amp fast (10 pc's.)	4001
S43561	Fuse glass 2 amp slow (10 pc's.)	4001
S59208	PC board display	4002
S100455	Cable set complete wiring harness	4003
S59430	Main fuse10A slow acting (5 pc's.)	4003
S101528	Fan/Blower Fuse 12A slow acting (5 pc's)	4003
S59429	Fuse holder FPG2	4003
S100456	Flat cable	4004
S59245	On/off switch (5 pc's.)	4005
S100457	Ignition/ ionization cable with cap & grommet	4006
S100458	Front cover instrument panel	4007
S100459	Top cover instrument panel	4008
S59238	Cover plate compensating controller	4009
S100419	Casing panel handle	4010
57350	Screw control cover m4 x10	4011
S57010	Spacer (10 pc's.)	4012
59436	Cable Flue gas damper (option)	4096
S38187	Fuse 1 amp slow acting (10 pc's.)	4001

Please contact your local De Dietrich Authorized Representative or Dealer for spare parts, pricing and delivery, if you do not know who your local dealer is, DDR Americas Inc. – De Dietrich @ 1.800.943.6275

16 ADDENDICES

16.1 Control menu

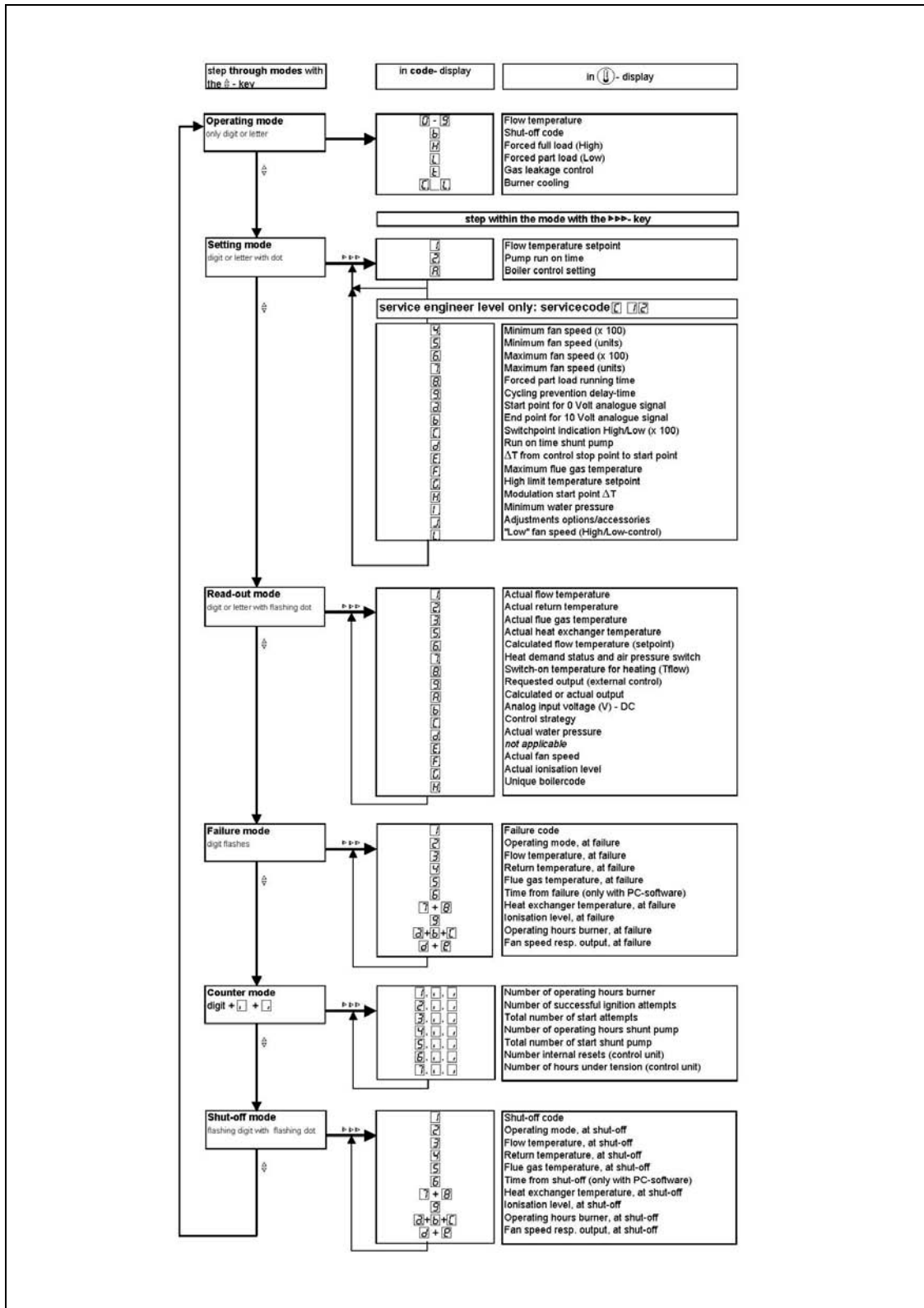

Fig. 40 Control menu flow chart

16.2 Shut-off codes

Code	Description	Cause/Check
b 0.8	Insufficient air transport during pre-purge. The boiler is locked after 5 restarts (6 starts) with code (see section 14.4)	- Air supply or flue gas discharge for blockages or installation faults - Air pressure differential sensor and connections
b 2.4	T_{return} is higher than $T_{flow} + 35^{\circ}\text{F}$ [2°C] (e.g. 199°F [93°C] if T_{return} is 194°F [90°C]) for more than 10 minutes (and the boiler has been running at minimum load for 10 minutes). The shut-off is lifted when T_{return} is $<$ or equal to $T_{flow} + 37^{\circ}\text{F}$ [3°C], e.g. 197°F [92°C].	- Flow and return sensors have been swapped. - Flow and return pipes have been swapped.
b 2.5	Maximum acceptable ascension speed of the boiler block temperature has been exceeded. The boiler shuts down for 10 minutes, after 5 consecutive start attempts within one heat demand, shut-off is recorded in the failure register as a fault, the boiler lock-out or go into failure mode.	- Whether heating pump is running - If there is water flow through the boiler - Sufficient water pressure
b 2.6	(Only with optional minimum gas pressure switch) Activation of minimum gas pressure switch, the shut-off is automatically reset when pressure returns above minimum setpoint.	- Main gas cock closed - Insufficient gas supply pressure or set point - Wiring
b 2.8	Fan not running	- Fan defective - Fan cable or connector is corroded, resulting in absence of voltage or control signal
b 2.9	Fan continues to run or signal incorrect	- Check the fan cable connectors on both the fan side and the automatic control unit side - Fan electronics defective - Excessive negative chimney pressure
b 3.0	Maximum acceptable difference between the flow and return temperatures has been exceeded. The boiler shuts down for 150 seconds, after 20 consecutive start attempts within one heat demand the shut-off is recorded in the failure register as a fault, the boiler does not lock-out or go into failure mode.	- Whether the heating pump is operating - If there is water flow through the boiler - Sufficient water pressure
b 3.8	Air pressure differential sensor short circuited, after 4 restarts the shut-off goes into failure mode	- Check the cable for short circuit - Sensor is defective
b 3.9	Air pressure differential sensor open, after 4 restarts the shut-off goes into failure mode	- Check cable and connections - Sensor is defective
b 4.3	One or more parameter(s) are out of limits	- Incorrect parameters set in control
b 4.5	(Optional item) Hydraulic pressure sensor short circuit	- Check sensor cable for short circuiting, etc.. - Sensor is defective
b 4.6	(Optional item) Hydraulic pressure sensor open	- Check sensor cable for proper connection - Sensor short circuiting or is defective

16.2 Shut-off codes (Continued)

b 5.2	Maximum flue gas temperature has been exceeded. The boiler shuts down for 150 seconds, followed by a restart. If the flue gas temperature rises 41°F [5°C] above the maximum flue gas temperature, a lockout follows with code 5.2 (see section 14.4)	<ul style="list-style-type: none"> - Poor or blocked chimney conditions - Boiler heat exchanger requires maintenance - Max flue gas temperature setting in correct
b 6.1	Air pressure differential sensor not opening	<ul style="list-style-type: none"> - Sensor defective - Connected, short circuiting - Poor or blocked chimney conditions
b 6.2	(Only with optional hydraulic pressure sensor, Optional) Water pressure is too low. The boiler is forced to shut-off when the minimum water pressure is below the minimum pressure. The shut-off automatically resets when the water pressure returns.	<ul style="list-style-type: none"> - System pressure too low or water content - leak in water system - Defective sensor - Connection, wiring or short circuit
b 8.8	Shut-off input is open, when the input is closed, the shut-off is reset	<ul style="list-style-type: none"> - Remove cause of shut-off
b 9.4	Maximum acceptable difference between boiler shut-off temperature and flow temperature has been exceeded. The boiler shutdown for 10 minutes, after 5 consecutive starts attempts within one heat demand the shut-off is recorded in the failure register as a faultm the boiler does not go into failure mode.	<ul style="list-style-type: none"> - Flow - Pumps - 3-way valves
b 9.9	Boiler releases contact is open	<ul style="list-style-type: none"> - Jumper missing, open contact - 3-way valve release contact not made

Table 25 Shut-off codes

17 BOILER COMMISSIONING REPORT & MAINTENANCESCHEDULE

17.1 – Boiler Commissioning Report

LOCATION OF INSTALLATION									
Address									
City-Town		Province or State			Country				
Mail Code		Phone #			E-Mail				
Installer		Company			Phone #				
EQUIPMENT DETAILS									
Boiler Model		Serial #		Control Model			Serial #		
Burner Model		Serial #		Firing					
Relief Valve		Size		Capacity Mbtu/h					
Chimney Type		Size		LWCO Device					
Vent Safety Device									
Other Controls		Shunt Pump			Size				
FLUE GAS EMISSIONS									
Fuel Type		Input Rate Gph or MBtu/h			Min		Min		
Item		Min Rate		Max Rate		Min Rate		Max Rate	
Air Setting - Index						CO ₂ & O ₂ [%]			
Head Setting - Index						CO [ppm]			
Supply Pressure In. w.c. or psig						NO _x [ppm]			
Fuel Pressure In. w.c. or psig						Smoke-VOC-PM ₁₀			
Breach Pressure In. w.c. [mbar]						Ambient [°F or °C]			
Chamber Press. In. w.c. [mbar]						Flue Gas Temp. [°F-°C]			
Supply-Return Temp [°F or °C]						Gross Combustion Efficiency [%]			
Control Safety Checklist									
Item		Set Point		Tested		Note			
Safety Hi-Limit				<input type="checkbox"/>					
Hi-Limit				<input type="checkbox"/>					
Operating Limit				<input type="checkbox"/>					
LWCO				<input type="checkbox"/>					
LGP switch				<input type="checkbox"/>					
HGP switch				<input type="checkbox"/>					
Vent Device				<input type="checkbox"/>					
Aux. Safety				<input type="checkbox"/>					
Analyzer Print-outs									

To successfully activate the boiler warranty a copy of this startup report must be returned to us to keep on file.

Mail:

DDR Americas Inc.
1090 Fountain Street, North, Unit 10
Cambridge, Ontario, Canada N3E 1A3
Attention: Service Manager

Email: craig@dedietrichboilers.com

Website: www.dedietrichboilers.com

Facsimile: 519.650.1709 **Tel:** 519.650.0420

17.2 Boiler Control Settings

Site Applied Boiler Control Settings: [Setting Mode]					
1.		2.		3.	
Advanced Setting Mode – Service Level					
4.		5.		6.	
7.		8.		9.	
10.		11.		12.	
13.		14.		15.	
16.		17.		18.	
19.		20.		21.	

17.3 Routine Boiler Maintenance Checklist [Typical] – Does not respect all installations, guideline °only

Responsible	f	Description	Schedule
Owner should at least be familiar with what items or areas need periodic attention and maintenance, the licensed and authorized service personnel shall inform the owner what symptoms to be aware of and course of action		System pressure 11 – 100 psi	Monthly
		Control functioning	Monthly
		Seals or evidence of leaks	Monthly
		Unobstructed combustion air supply, no chemicals, garbage, gasoline, other combustible materials or flammable liquids are stored near the boiler.	Monthly
		Check for water on the floor – around relief, vent and other parts and piping of the water system	Monthly
		Check operating limits for correct operation	Semi-annually
		Ensure neutralization system is working	Semi-annually
		Check exhaust terminals for ice, snow or debris buildup	Monthly
		Check and test pressure relief safety valve	Annually
		Check PH levels of condensate	Annually
		Test temperature Hi limit functions	Annually
		Checks for system leaks	Monthly
		Check all auxiliary and other safety limits for function and correct operation.	Annually
		Check system water quality	Monthly
		Check pump °operation	Monthly
		Check fuel lines for leaks	Annually
		Check combustion	Annually
		Check control settings	Annually
	Clean combustion chamber	Annually	
	Clean condensation collector and siphon	Annually	



DDR Americas Inc.

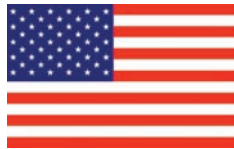

1054 North DuPage Avenue
Lombard, Illinois 60148 USA
Tel: 630-953-2374 / Fax: 630-953-2376



1090 Fountain Street North, Unit 10
Cambridge, Ontario N3E 1A3 Canada
Tel: 519-650-0420 / Fax: 519-650-1709

Toll Free: 800-943-6275

www.dedietrichboilers.com

info@dedietrichboilers.com